

Product Assembly Instructions

Item#: WINSLOW BAR HEIGHT TABLE WINSLOW COUNTER HEIGHT TABLE







Helpers needed to assemble: 2

Estimated time frame to assemble: 15 minutes

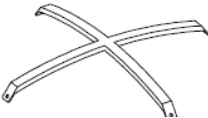
Thank you for purchasing this quality product. Be sure to check all packing material carefully for small parts, which may come loose inside the carton during shipment. Please identify and count all parts and compare with the HARDWARE LIST below.

Caution: Please read instructions carefully before unpacking assembly parts. Sharp, exposed staples can cause injury, therefore, for your protection, please remove any exposed staples used in packing.

*** Retain the Allen key for regular maintenance. We recommend tightening all screws every three months to ensure continued stability and performance. ***

#	Picture	Description	Q'TY.
A		Leg	4
B		Base X-Frame	1
C		Shelf	1
D		Top X-Frame	1
E		Table Top	1
1		Ø1/4" x 13mm Bolts	16
2		Allen Key	1

Before beginning assembly, place all parts on a smooth, flat surface.

Step 1 – Attach First Two Legs to Base X Frame

- Position two **Leg (A)** and **Base X-Frame (B)**.
- Align the holes carefully.
- Secure using **Ø1/4" × 16 mm Bolts (1)**.
- Tighten lightly with the provided **Allen key (2)**.

Step 2 – Install Shelf .

- Attach the **Shelf (C)** to the two assembled **Leg (A)**.
- Align the holes before inserting bolts.
- Secure with **bolts (1)** and tighten using **Allen key (2)**.

Step 3 – Install Top X-Frame.

- Attach the **Top X - Frame (D)** to the assembled leg structure.
- Insert **bolts (1)** through aligned holes.
- Tighten using **Allen key (2)**.

Step 4 – Attach Remaining Legs.

- 1 Position the remaining two Legs (A) onto:
 - **Base X-Frame (B)**
 - **Shelf (C)**.
 - **Top X-Frame (D)**.
- 2 **Insert bolts (1)** and tighten securely with **Allen key (2)**.

Step 5 – Attach the Table Top.

- Carefully turn the **Table Top (E)** upside down onto a soft surface.
- Position the assembled base onto the table top holes.
- Secure with **bolts (1)** and tighten fully using **Allen key (2)**.

Assembly Complete

Your **Winslow Height Table** is now ready for use.

STEP 1

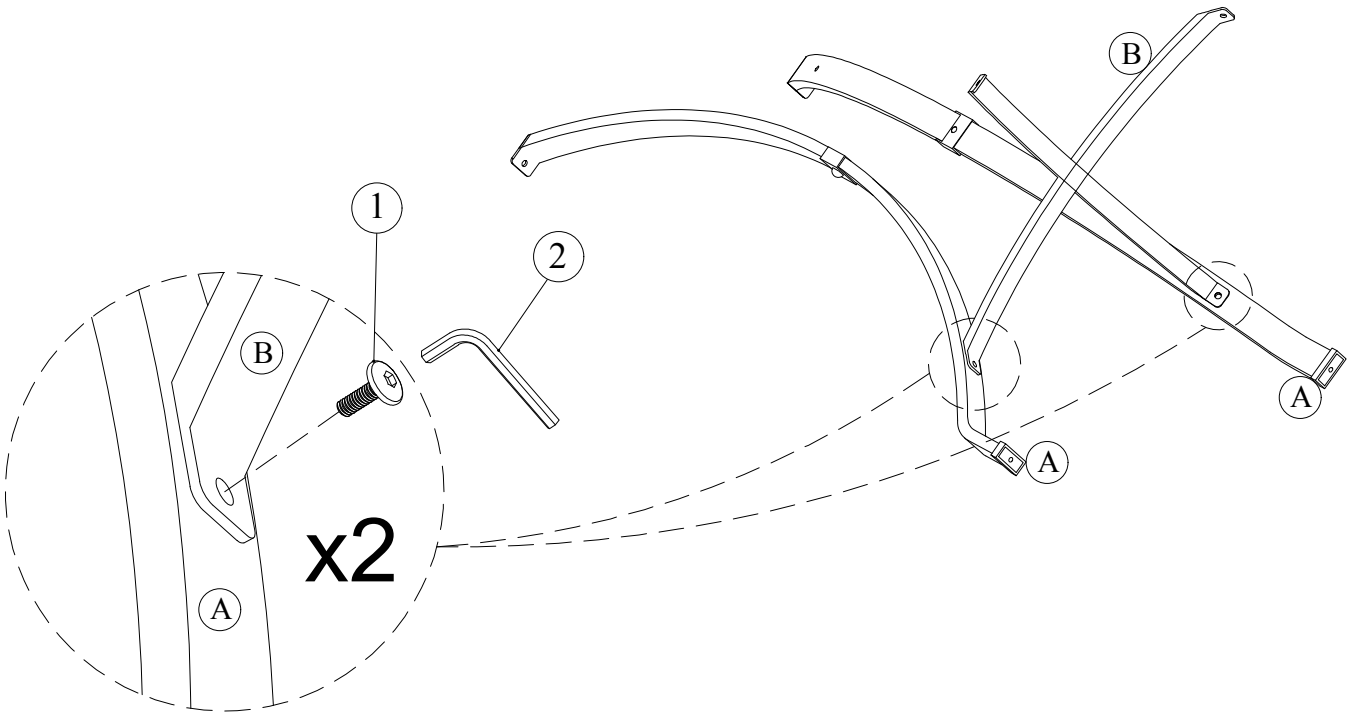

STEP 2

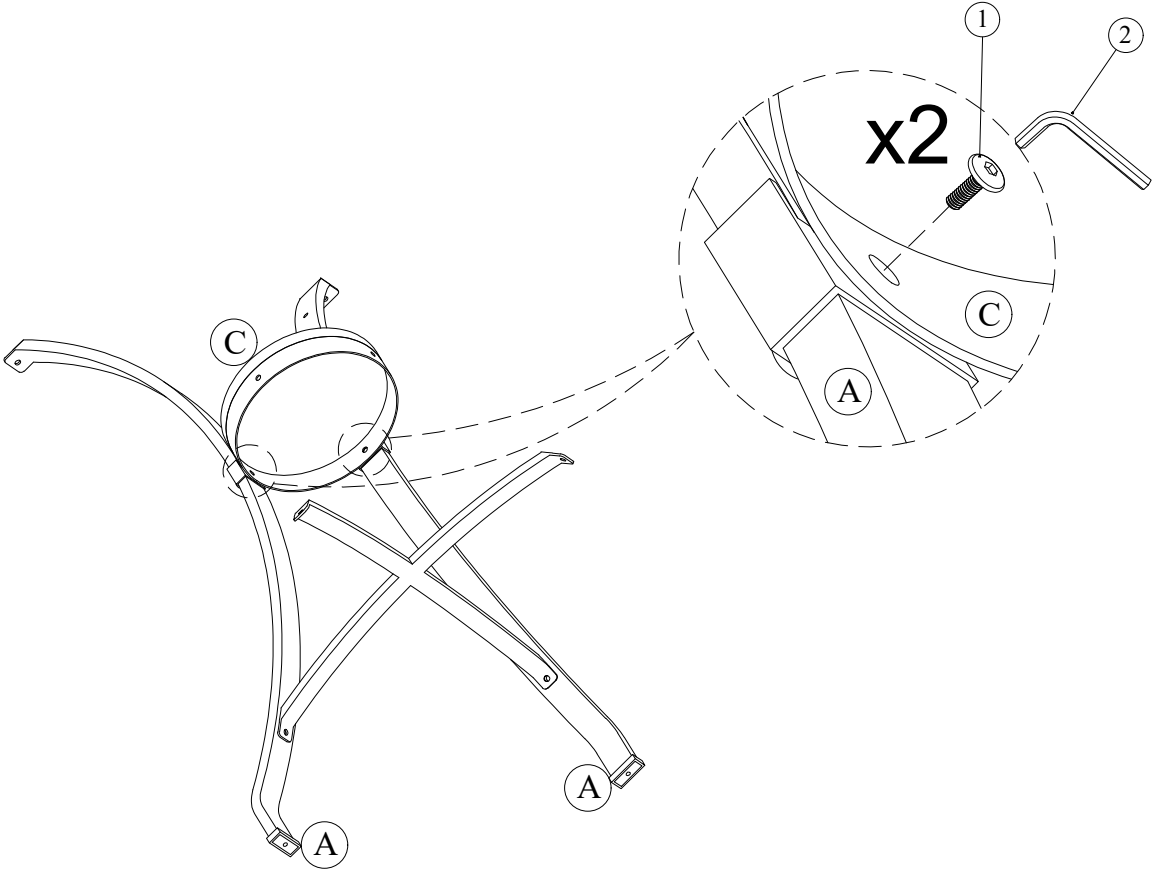

STEP 3

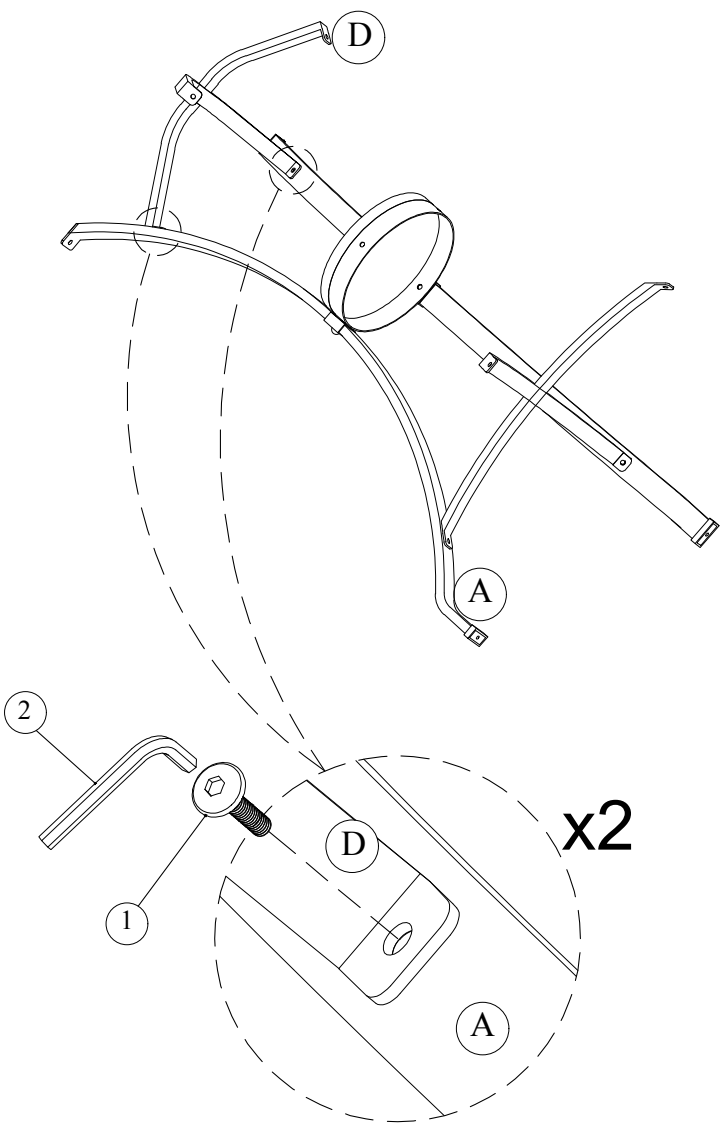

STEP 4

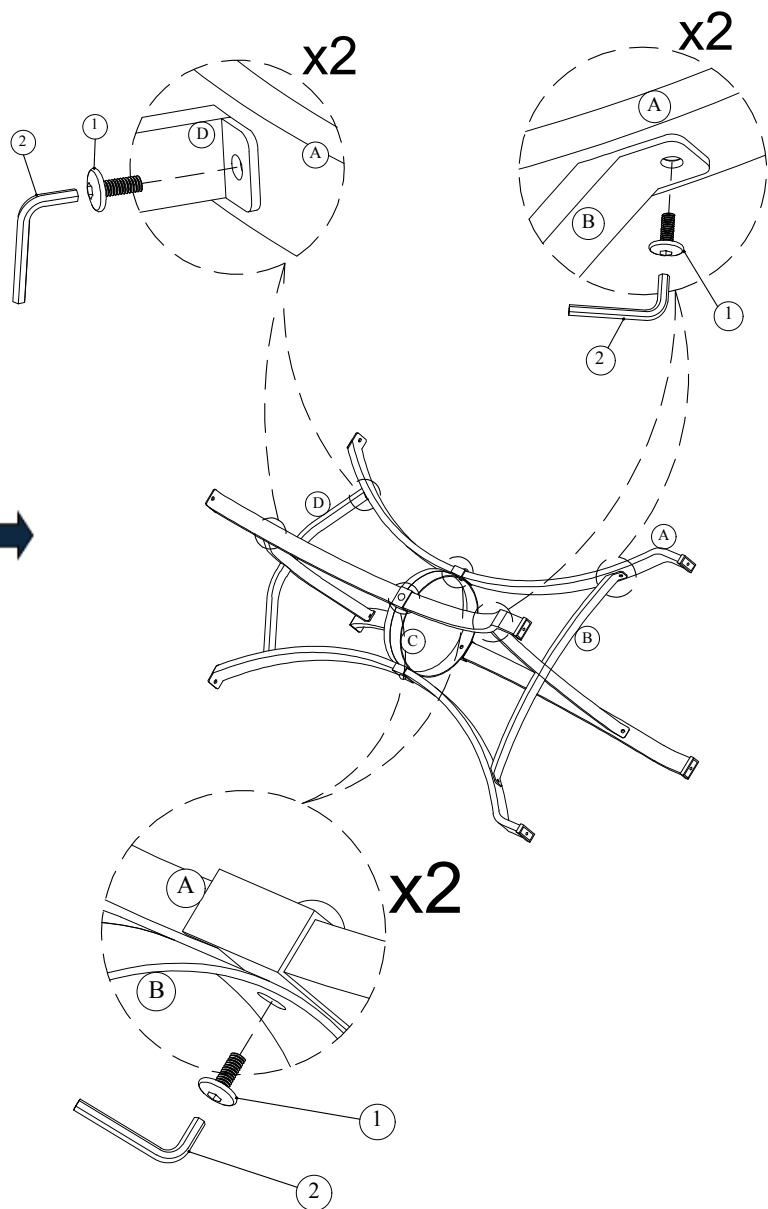

STEP 5

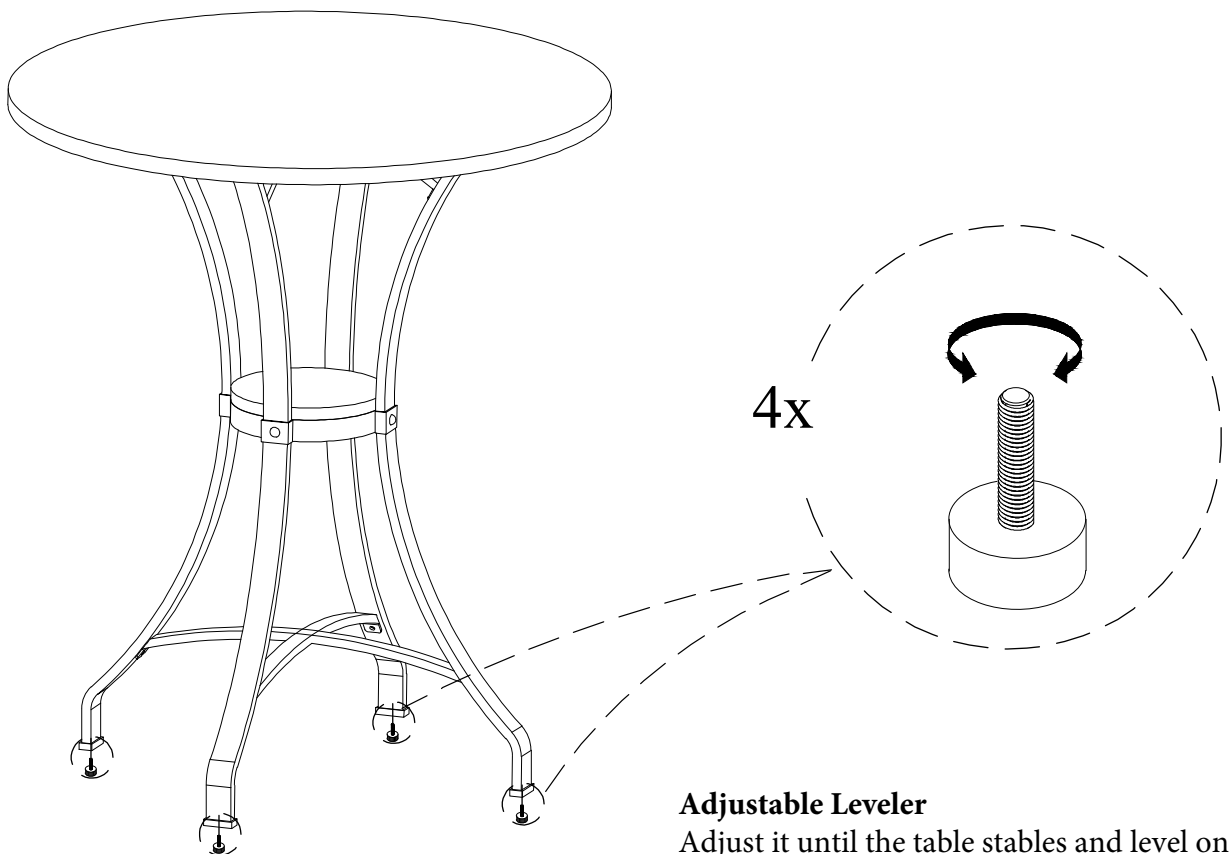
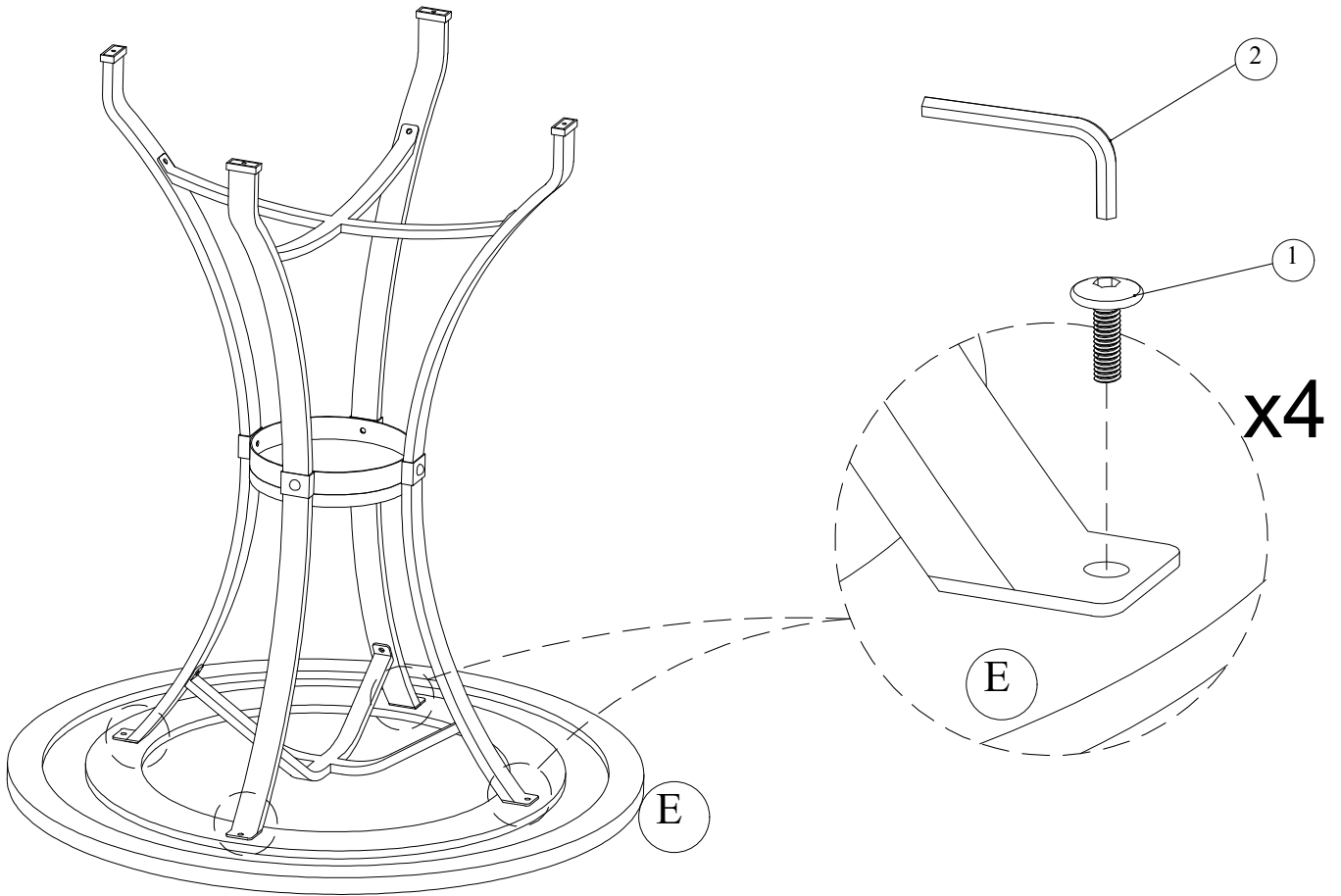

Adjustable Level
Adjust it until the table stables and level on the floor.

Product Assembly Instructions

Item#: WINSLOW BARSTOOL

Helpers needed to assemble: 2

Estimated time frame to assemble: 10 minutes

Thank you for purchasing this quality product. Be sure to check all packing material carefully for small parts, which may come loose inside the carton during shipment. Please identify and count all parts and compare with the **HARDWARE LIST** below.

Caution: Please read instructions carefully before unpacking assembly parts. Sharp, exposed staples can cause injury, therefore, for your protection, please remove any exposed staples used in packing.

* **Retain the Allen key for regular maintenance. We recommend tightening all screws every three months to ensure continued stability and performance. ***

Before beginning assembly, place all parts on a smooth, flat surface.





Step 1 – Attach Seat Frame

- Place the **Leg Frame (A)** upside down on a soft surface.
- Attach the **Seat Frame (B)** to the **Leg Frame (A)**.
- Secure using **Ø1/4" x 44 mm bolts (1)**, **flat washers (2)**, and **spring washers (3)**.
- Ensure all holes are properly aligned before fully tightening the bolts.
- Tighten securely using the provided **Allen key (4)**.

Step 2 – Install Cushion

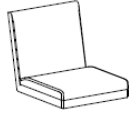
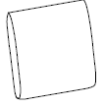
- Turn the barstool upright.
- Place the **Pillow (C)** onto the **Seat Frame (B)**.

Assembly Complete — Enjoy your Winslow Barstool!

#	Picture	Description	Q'TY.
A		Leg Frame	1
B		Seat Frame	1
C		Pillow	1
1		Ø1/4" x 44 mm Bolt	4
2		Ø16/Ø6 Flat washer	8
3		Ø1/4" Spring washer	8
4		Allen key	1

STEP 1

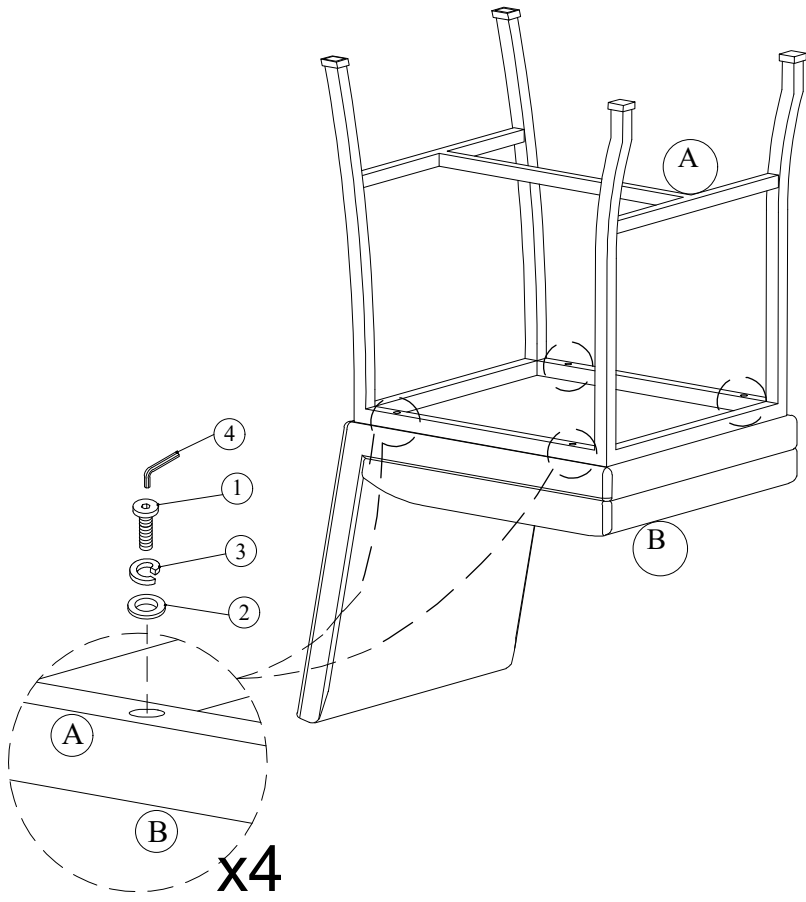

STEP 2

