

Product Assembly Instructions Item#: SANTORINI COUNTER HEIGHT TABLE









Helpers needed to assemble: 2

Estimated time frame to assemble: 15 minutes

Thank you for purchasing this quality product. Be sure to check all packing material carefully for small parts, which may come loose inside the carton during shipment. Please identify and count all parts and compare with the HARDWARE LIST below.

Caution: Please read instructions carefully before unpacking assembly parts. Sharp, exposed staples can cause injury, therefore, for your protection, please remove any exposed staples used in packing.

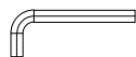
* Retain the Allen key for regular maintenance. We recommend tightening all screws every three months to ensure continued stability and performance. *

#	Picture	Description	Q'TY.
A		Leg Frame	4
B		Bottom Frame	1
C		Table Top	1
1		Ø1/4" x 13mm Bolt	8
2		Ø1/4" x 25mm Bolt	8
3		Ø16 / Ø7mm Flat Washer	8
4		Ø1/4" Spring Washer	8
5		Allen key	1
6		Leveler	8

Before beginning assembly, place all parts on a smooth, flat surface.

Step 1: Assemble Table Base

1. Position the **bottom frame (B)** on a flat surface.
2. Attach the **leg frames (A)** to the bottom frame:
 - Ensure leveling feet face downward.
 - Ensure pre-drilled holes face inward toward the frame.
3. Secure each leg frame using:
 - **Bolts (1)**
4. Tighten bolts lightly first. Final tightening will be done later.

Step 2 — Attach Table Top

1. Place the **Table Top (C)** upside down on a clean, soft surface.
2. Carefully position the assembled table base onto the **table top (C)**.
3. Align mounting holes.
4. Secure using:
 - **Bolts (2)**
 - **Spring washers (4)**
 - **Flat washers (3)**
5. Tighten all bolts securely using the **Allen key (5)**.

Step 3 — Assemble Leveler.

1. Attach the **leveler (6)** into the threaded hole.,
2. Turn the table upright carefully with two people.
3. Adjust the leveling feet if needed to ensure stability.

Maintenance Tip

- Periodically check and retighten all bolts (recommended every 3 months).

Assembly Complete!

Enjoy your new **Santorini Counter Height Table**

STEP 1

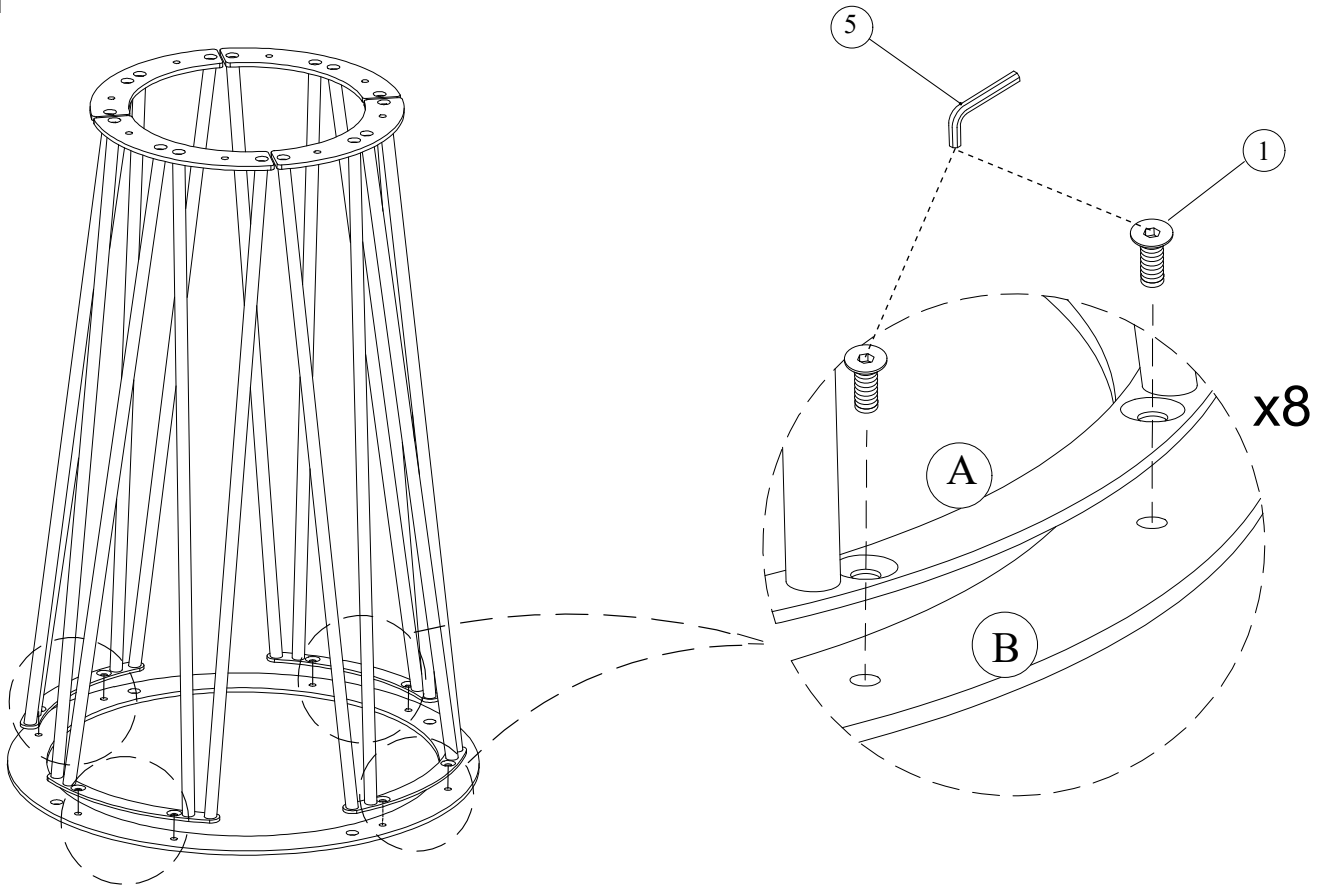

STEP 2

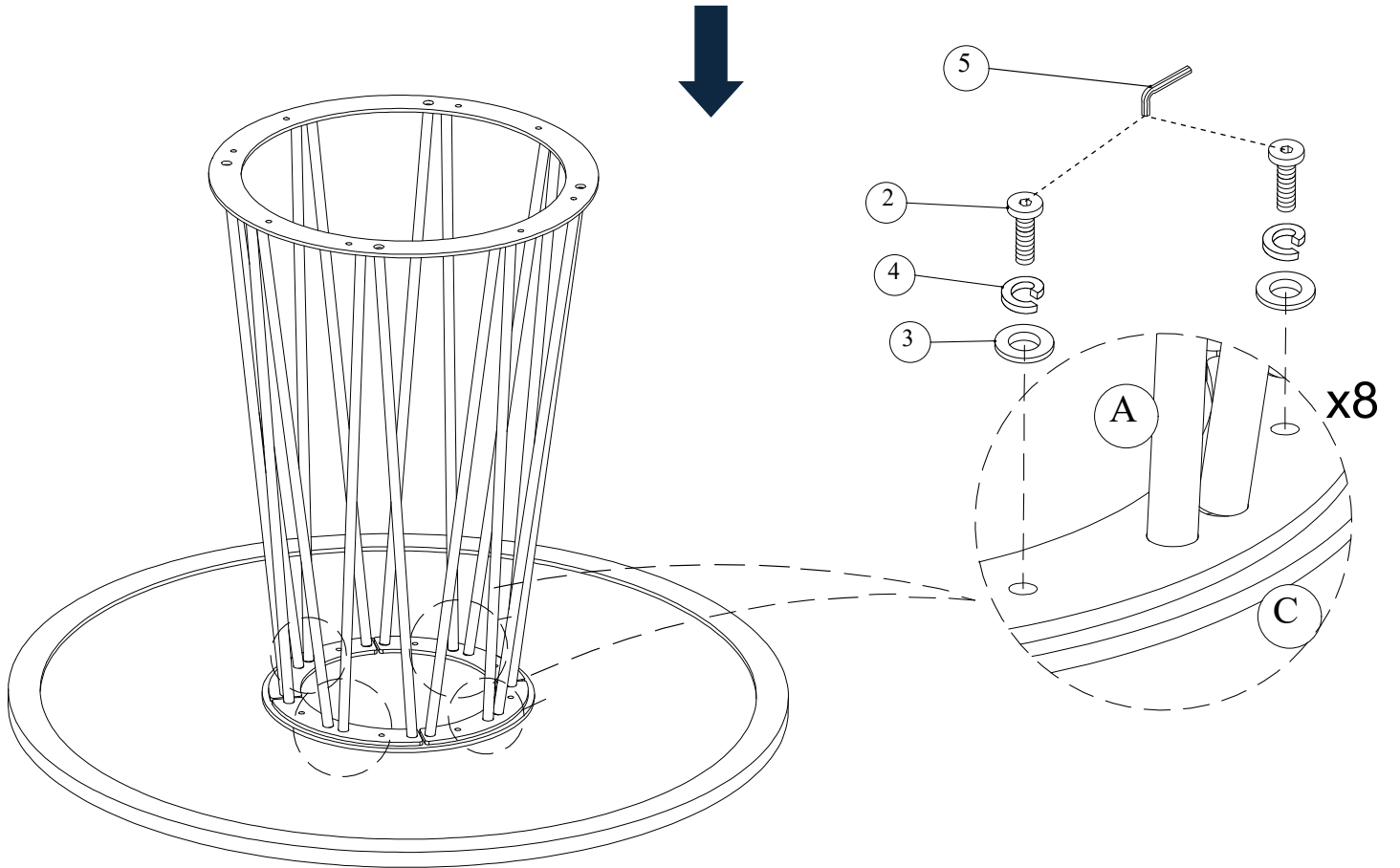

STEP 3

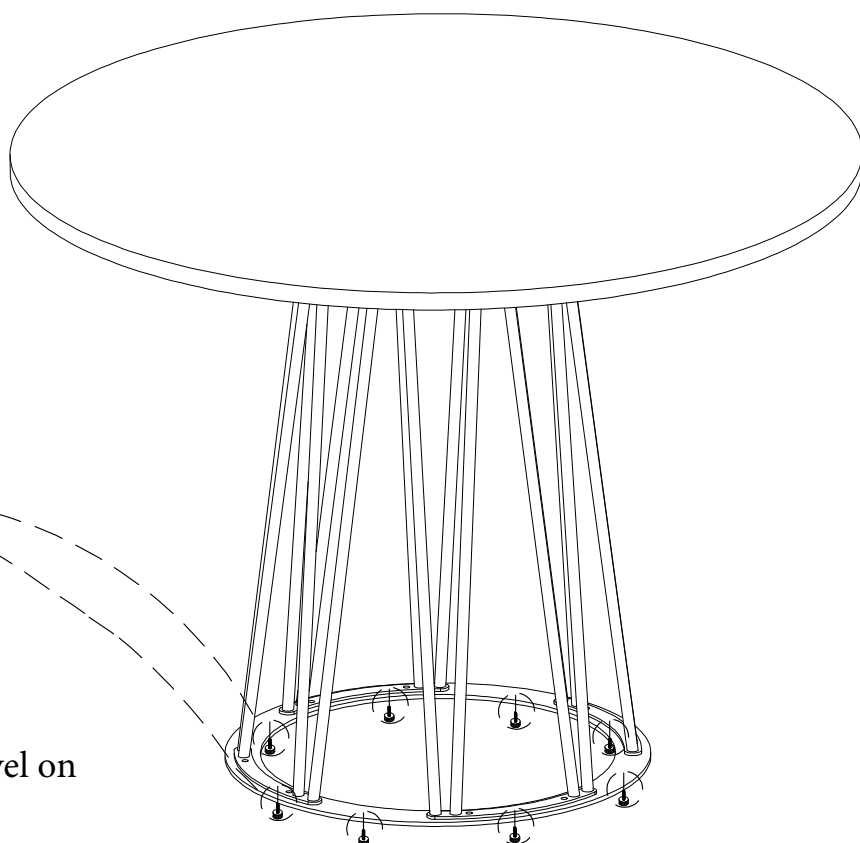
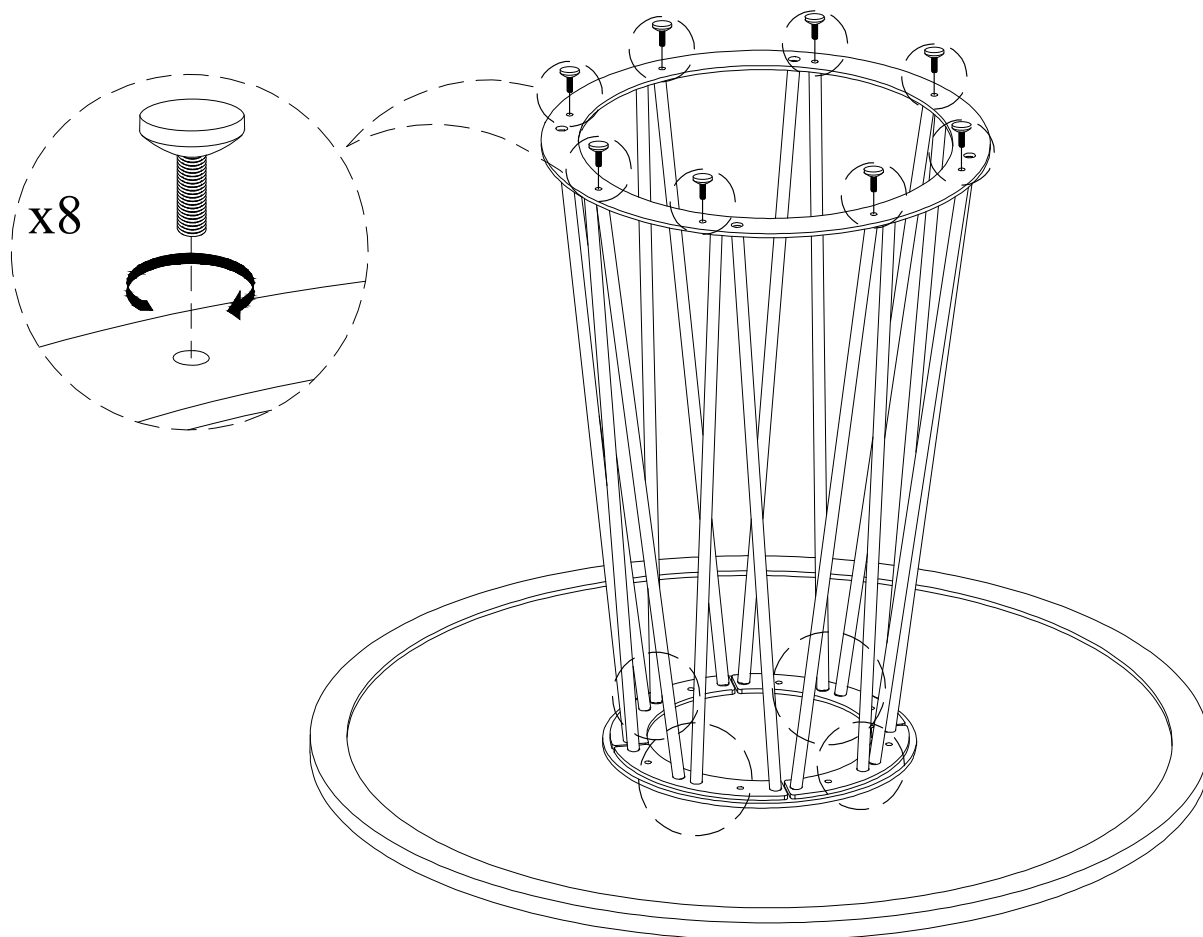

Adjust it until the table is stable and level on the floor.

Product Assembly Instructions

Item#: SANTORINI BARSTOOL

Helpers needed to assemble: 2

Estimated time frame to assemble: 10 minutes

Thank you for purchasing this quality product. Be sure to check all packing material carefully for small parts, which may come loose inside the carton during shipment. Please identify and count all parts and compare with the **HARDWARE LIST** below.

Caution: Please read instructions carefully before unpacking assembly parts. Sharp, exposed staples can cause injury, therefore, for your protection, please remove any exposed staples used in packing.

*** Retain the Allen key for regular maintenance. We recommend tightening all screws every three months to ensure continued stability and performance. ***

Step 1:







Before beginning assembly, place all parts on a smooth, flat surface.

Place the Seat Frame (B) upside down on a soft surface. Align the Frame Legs (A) with the pre-drilled holes on the swivel plate of the Seat Frame (B).

Insert 4pcs Bolts $\text{\O}1/4'' \times 1''$ (1) with Flat Washers (2) and Spring Washers (3) as shown, and tighten using the Allen Key (4).

Ensure the holes on the swivel plate are properly aligned with the holes on the Frame Legs (A) before fully tightening.

Your assembly is complete — enjoy your new barstool!

#	Picture	Description	Q'TY.
A		Frame leg	1
B		Seat frame	1
1		$\text{\O}1/4'' \times 1''$ Bolts	4
2		$\text{\O}1/4'' \times \text{\O}16$ Flat washer	4
3		$\text{\O}1/4'' \times \text{\O}10$ Spring washer	4
4		Allen key	1

STEP 1

