







# Product Assembly Instructions

## DESCRIPTION: DORADO DINING CHAIR

<p>① X1</p>  <p>Frame</p>	<p>② X1</p>  <p>Back</p>	<p>③ X1</p>  <p>M6 Wrench</p>
<p>④ X2</p>  <p>M6*20</p>	<p>⑤ X2</p>  <p>M6*40</p>	<p>⑥ X2</p>  <p>M6*55</p>
<p>⑦ X6</p>  <p>M6 spacer</p>	<p>⑧ X1</p>  <p>Seat cushion</p>	<p>⑨ X1</p>  <p>Back cushion</p>

STEP 1: Align the back plate with the holes, tighten the middle screw.

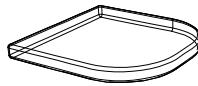
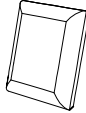
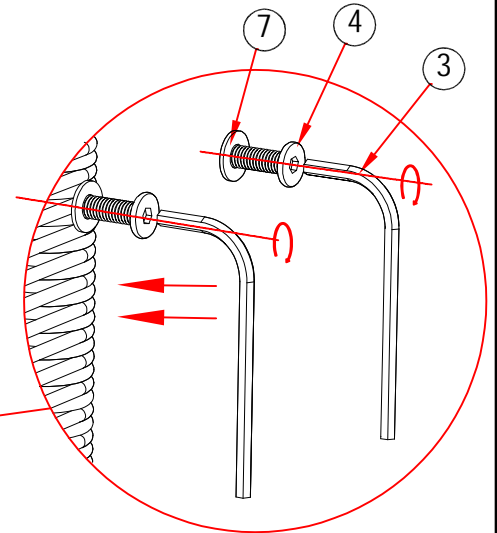
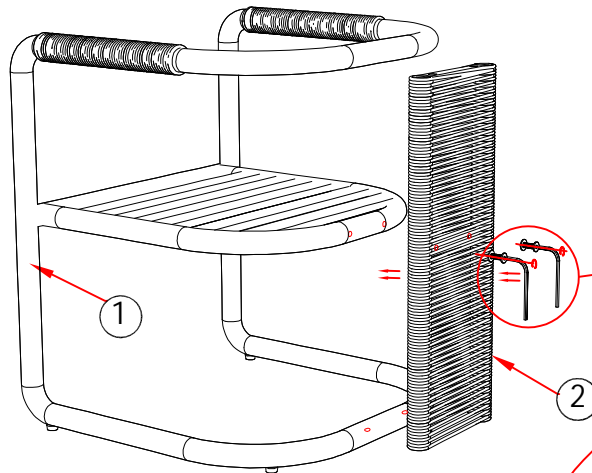
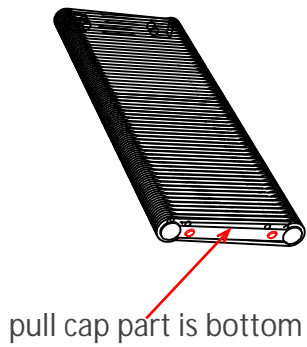

STEP 2: Turn the chair over, attach the pull cap part to the bottom, then assemble the screws on the top.

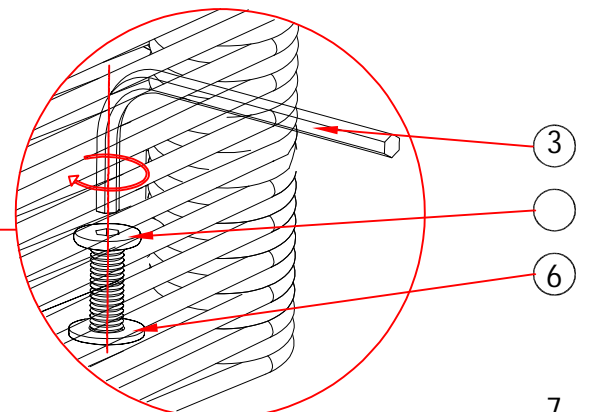
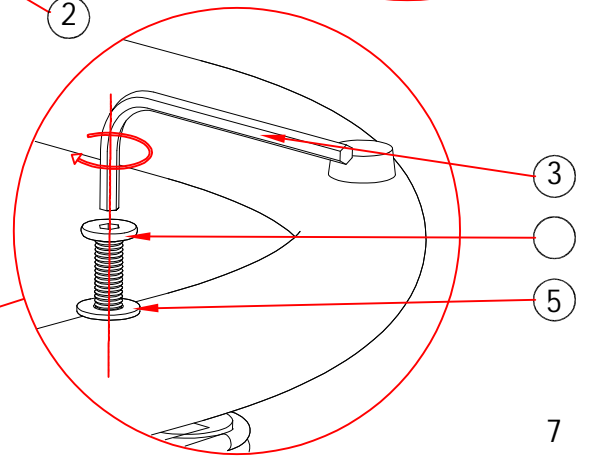
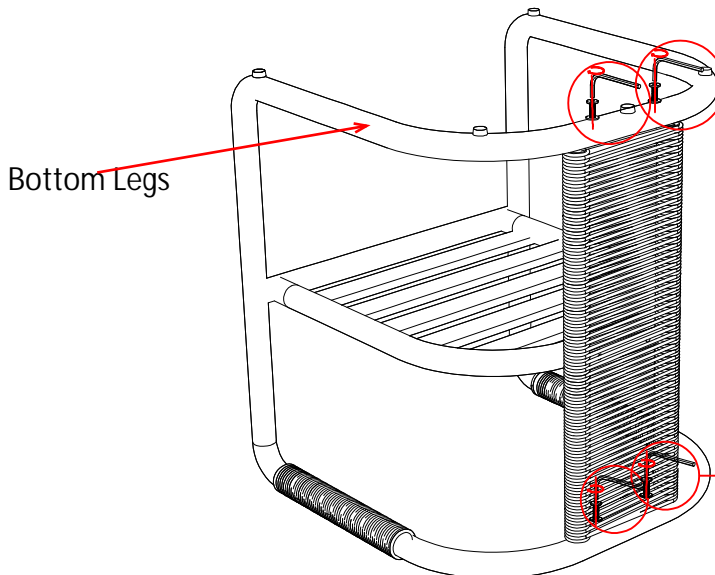

**Important Note:**  
Please finger tighten all bolts into position before fully tightening

# Product Assembly Instructions





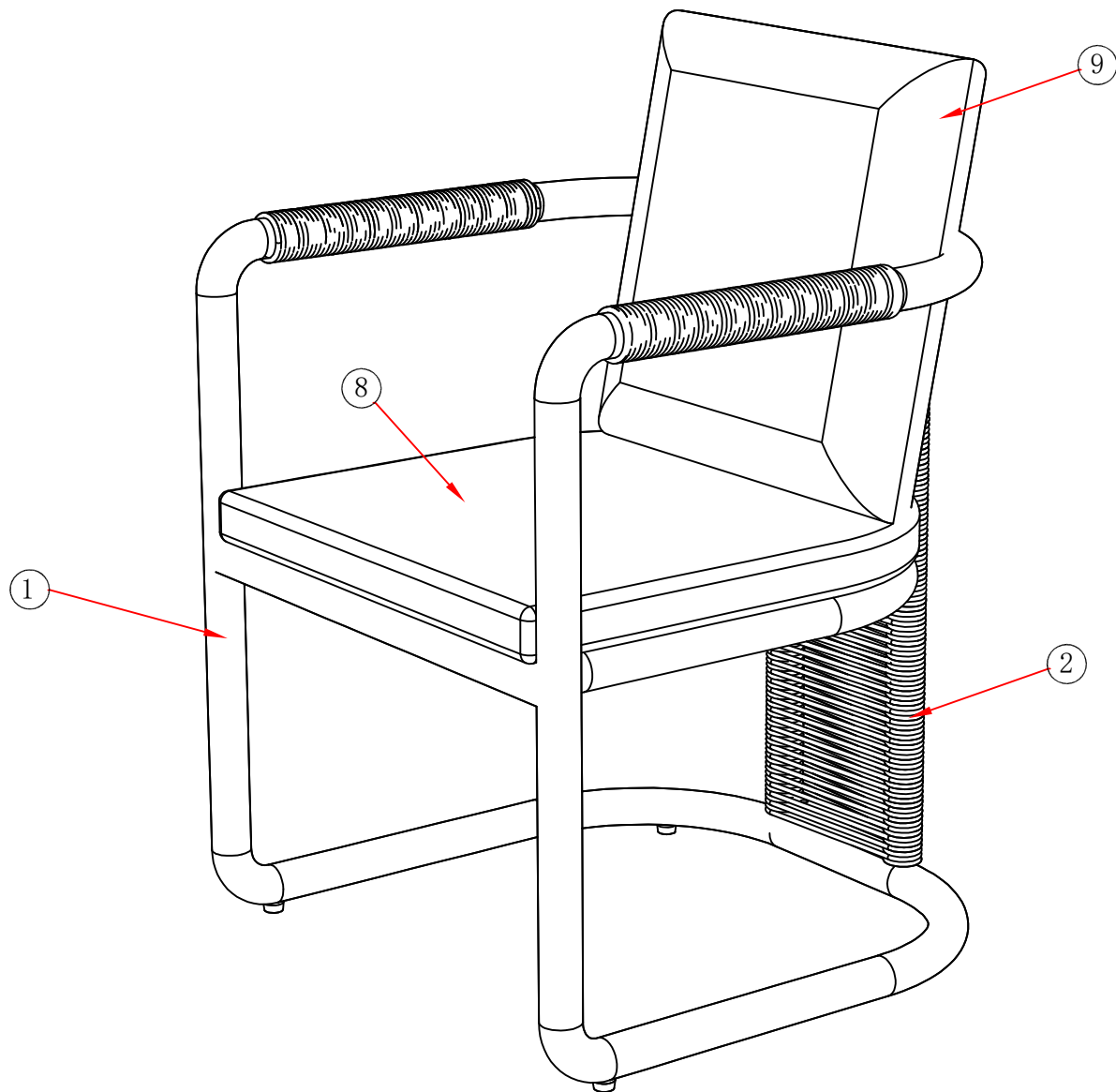

## DESCRIPTION: DORADO DINING CHAIR

STEP 3: put the cushions on the chair.

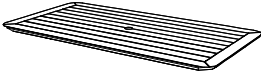
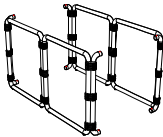
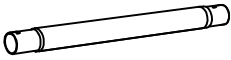
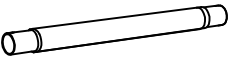

# Product Assembly Instructions

## DESCRIPTION: DORADO DINING TABLE

<p>① X1</p>  <p>Top</p>	<p>② X1</p>  <p>Leg</p>	<p>③ X2</p>  <p>Tubes under table top with 2 hole</p>
<p>④ X2</p>  <p>Bottom leg tube with 1 hole</p>	<p>⑤ X1</p>  <p>M6 Wrench</p>	<p>⑥ X4</p>  <p>M6*20 Screw</p>
<p>⑦ X4</p>  <p>M6*55 Screw</p>	<p>⑧ X8</p>  <p>M6 spacer</p>	<p>⑥ X1</p>  <p>Umbrella hole lid</p>

### STEP 1

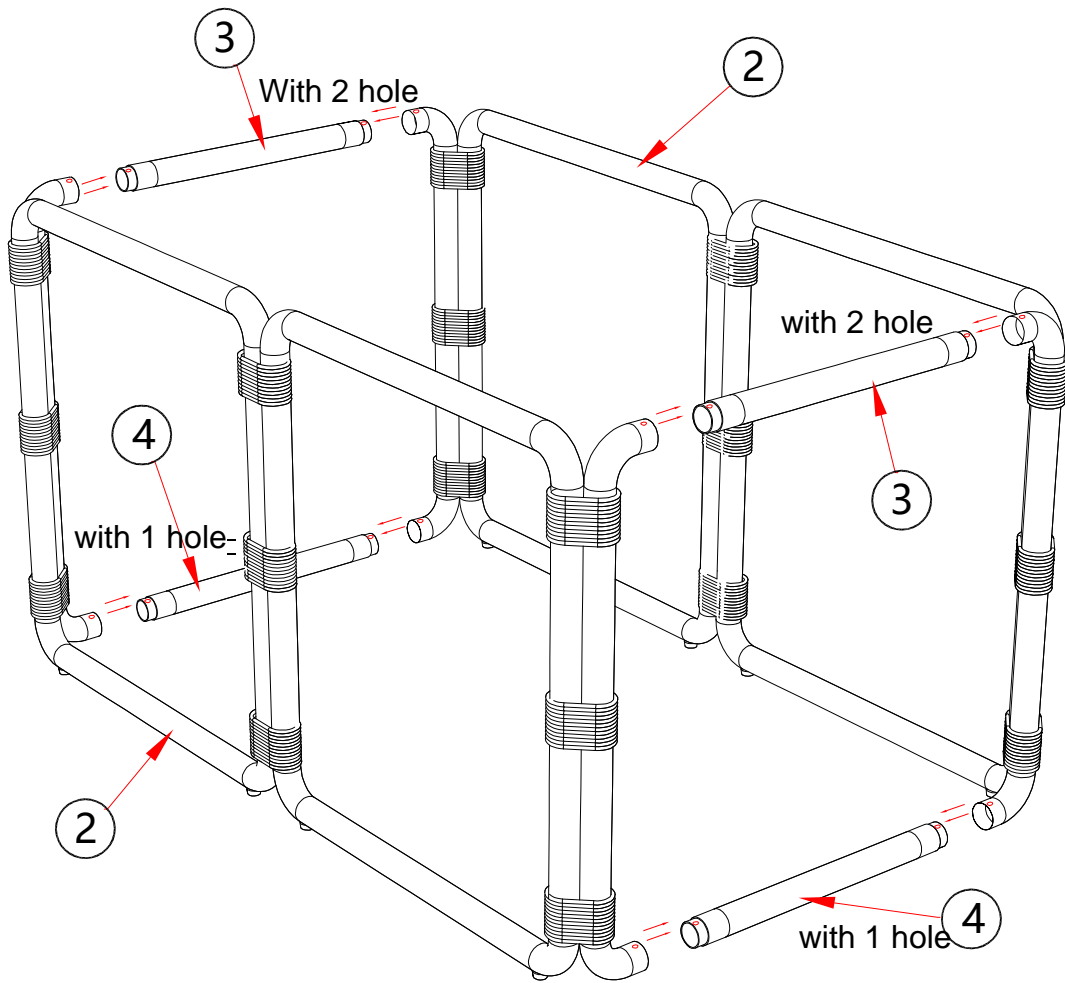

# Product Assembly Instructions

## DESCRIPTION: DORADO DINING CHAIR

### STEP 2

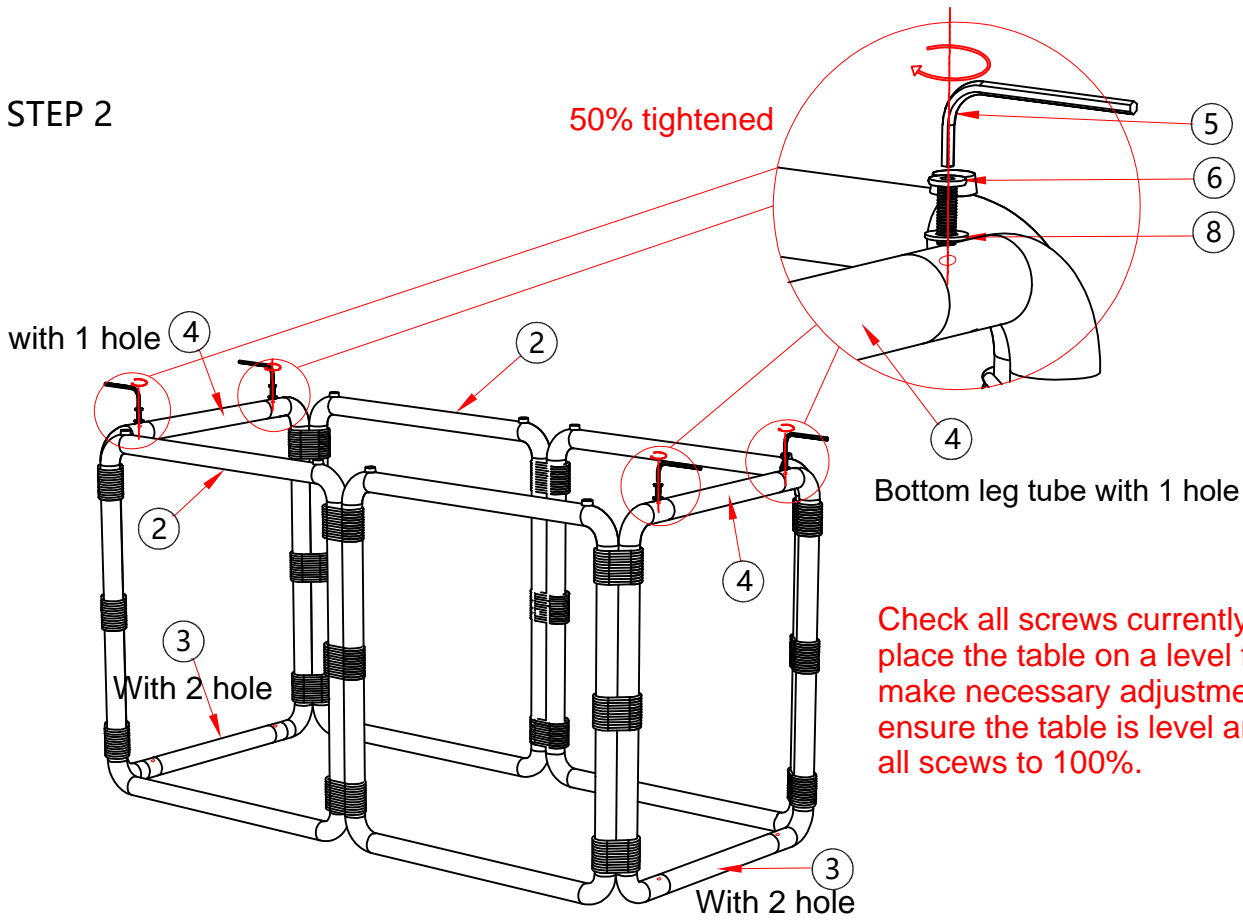

### STEP 3

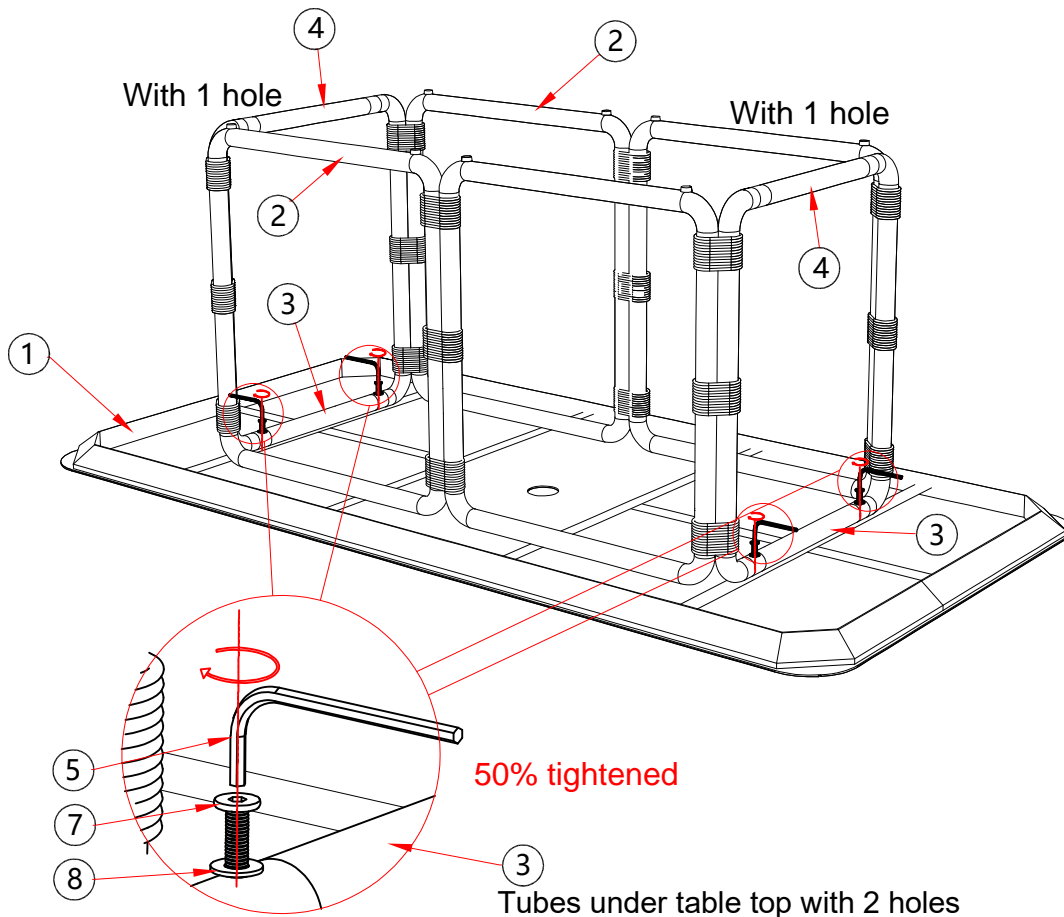

# Product Assembly Instructions

## Insert Factory Item #LCDDDIGRBZ

STEP 4

