



Product Assembly Instructions
LCCODIBLTOP/LCCODIBLBASE

PART LIST



A: TABLE TOP x1

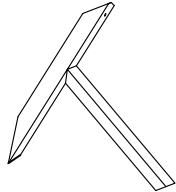

B: TABLE LEG x6

HARDWARE LIST



E: JCBC SCREW M6 x 40MM x6



F: JCBC SCREW M6 x 60MM(BLK) x6



G: SPRING WASHER 1/4" x6



H: SPRING WASHER 1/4"(BLK) x6



I: ADJUSTABLE SCREW x6



J: M4 ALLEN KEY (BALL SHAPE)LONG x1



K: WOOD DOWEL DIA 12 x 30MM x6

STEP 1

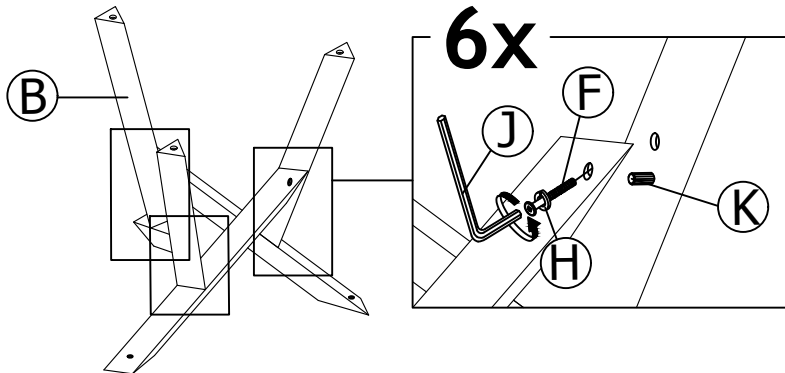

STEP 2

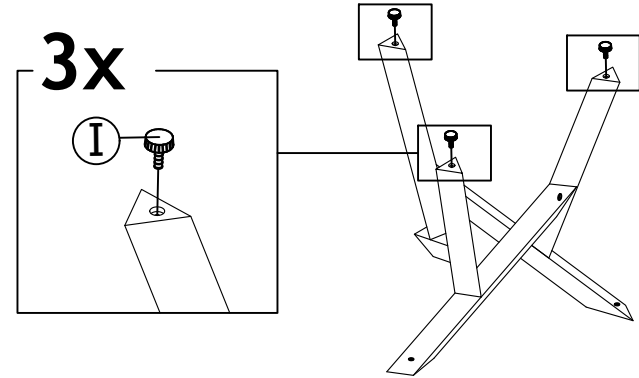

STEP 3

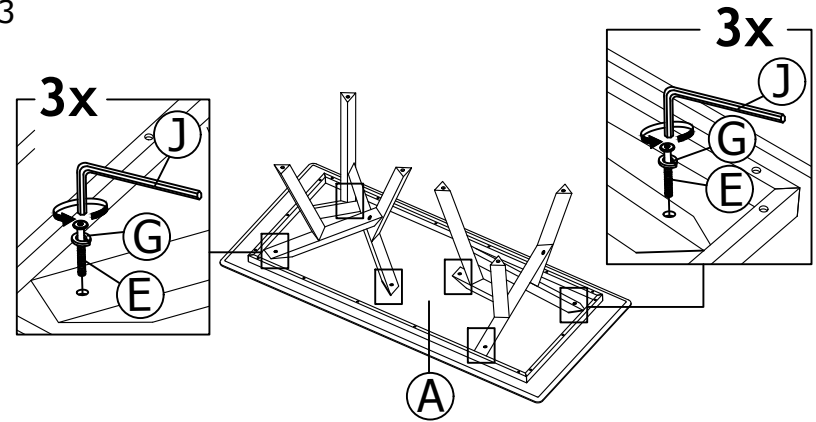

STEP 4

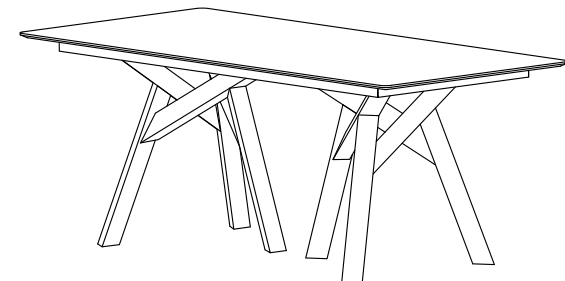



ASSEMBLY COMPLETED





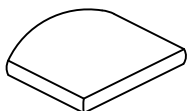

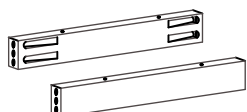

Product Assembly Instructions LCPLSIGRWA/LCPLSIGRBL

PART LIST

 A : CUSHION SEAT x1	 B : LEGS (R & L) x2	 C : BACK REST VENEER x1
 D : APRON (FRONT & BACK) x2		

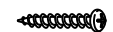
HARDWARE LIST

 E : JCBC SCREW M6 x 50MM x8	 F : JCBC SCREW M6 x 100MM x4	 G : SPRING WASHER 1/4" x12
 H : ALLEN KEY M4 (BALL SHAPE) x1	 I : PAN HEAD WOOD SCREW M5 X 32MM x4	 J : WOOD DOWEL DIA 8 x 35MM x6

STEP 1

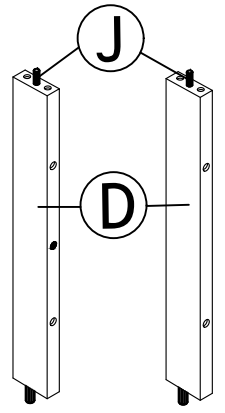

STEP 1.1

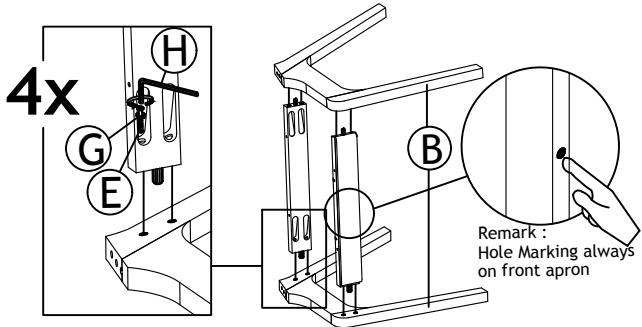

Remark :
Hole Marking always
on front apron

STEP 2

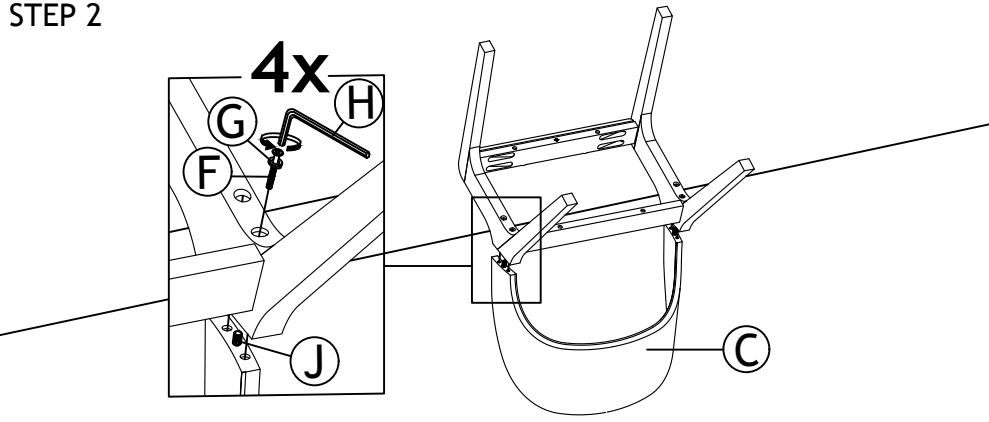

STEP 3

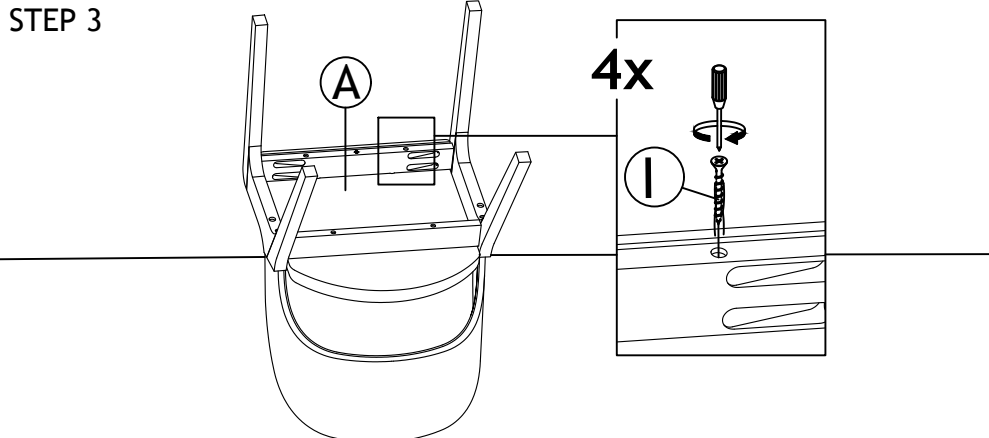

STEP 4

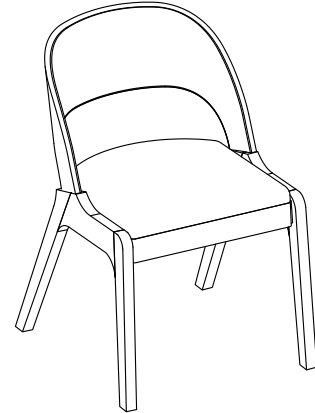

ASSEMBLY COMPLETED