

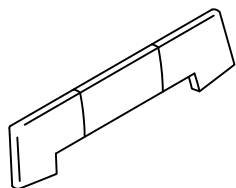

# Product Assembly Instructions

CHANNELL BENCH

## PART LIST



A : BACKREST x1

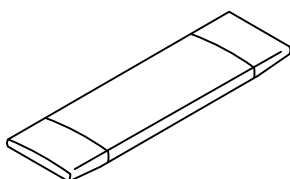

B : CUSHION SEAT x1

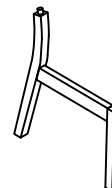

C : SIDE LEG (L & R) x2



D : SUPPORT x1

## HARDWARE LIST



E : JCBC SCREW M6 x 45mm x7



F : JCBC SCREW M6 x 70mm x4



G : SPRING WASHER 1/4" x11



H : M4 ALLEN KEY (BALL SHAPE) LONG x1

## STEP 1

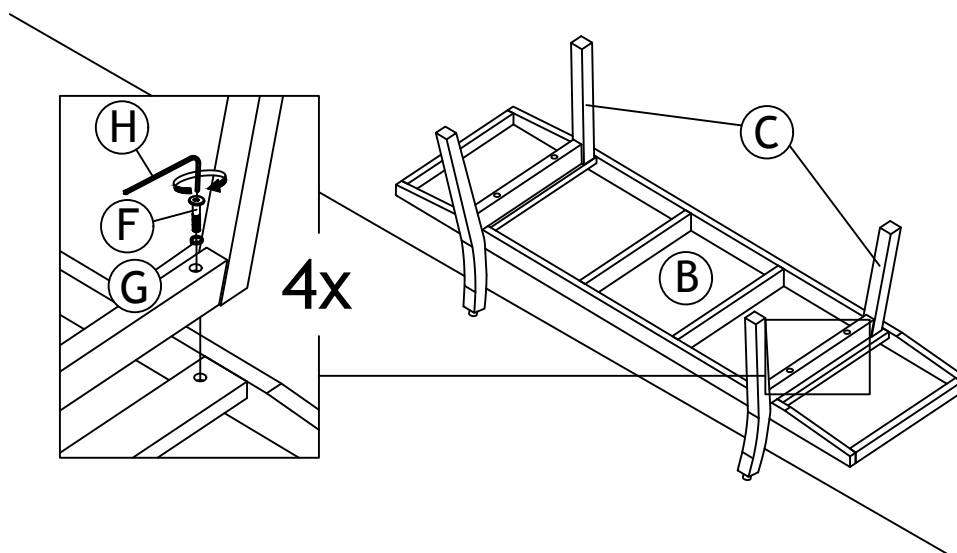

STEP 2

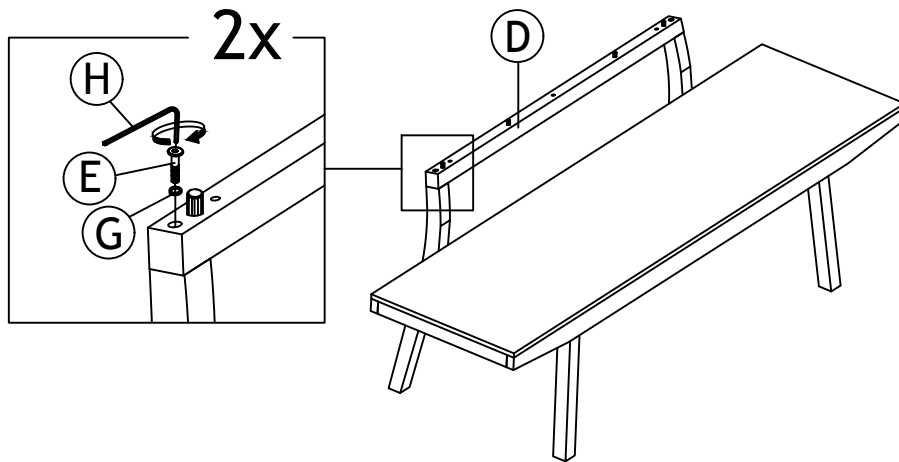

STEP 3

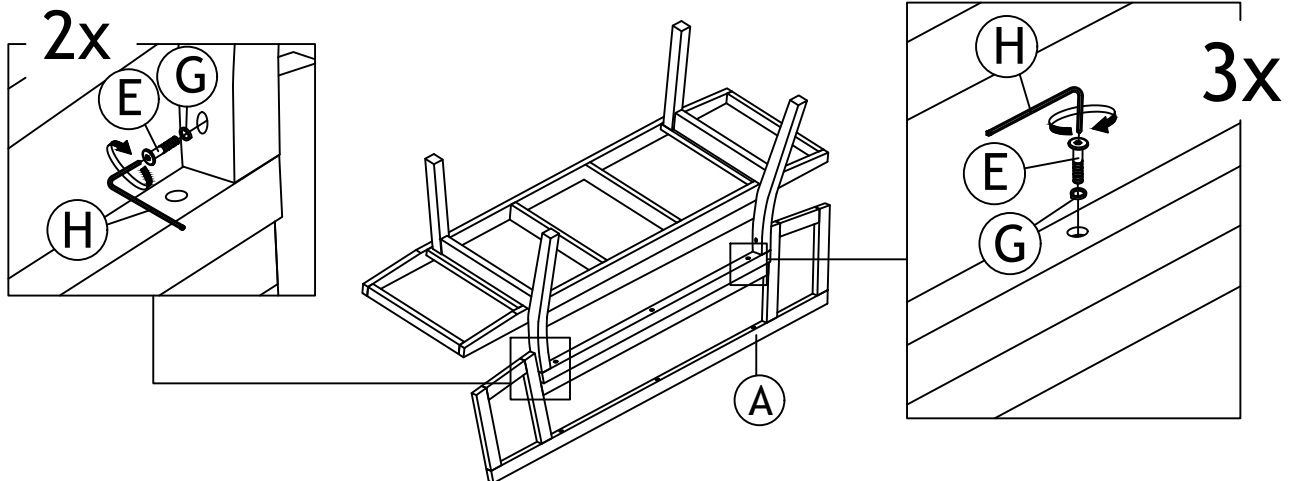

STEP 4

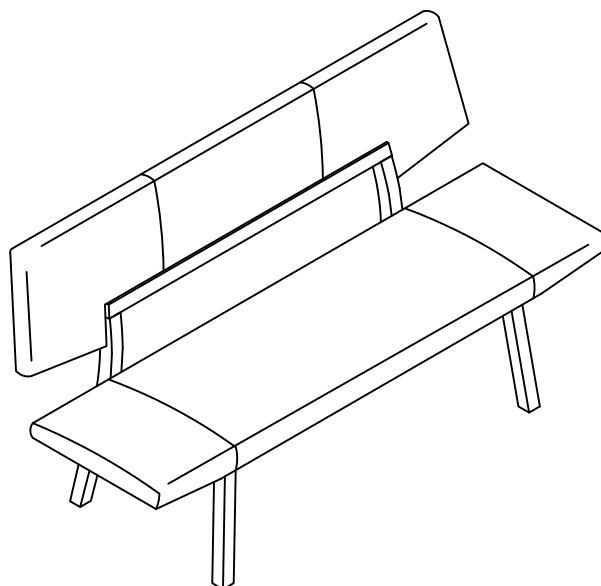



# Product Assembly Instructions

## CHANNELL DINING CHAIR

### PART LIST

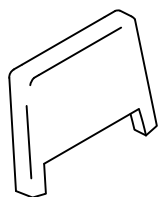

A : BACKREST x1



B : BACK LEG x1

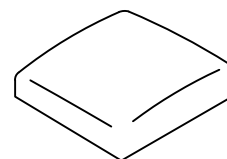

C : SEAT CUSHION x1

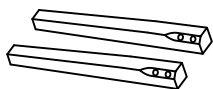

D : FRONT LEG (L &R) x2

### HARDWARE LIST



E : JCBC SCREW M6 x 45mm x12



F : SPRING WASHER 1/4" x12



G : FLAT WASHER 1/4" x8



H : M4 ALLEN KEY (BALL SHAPE) LONG x1

### STEP 1

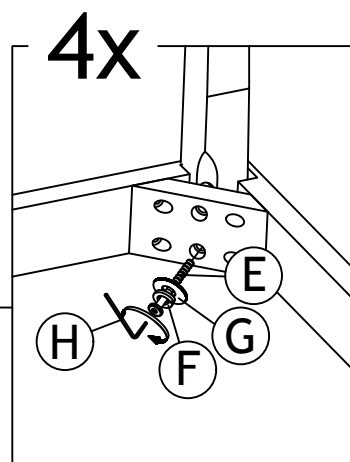
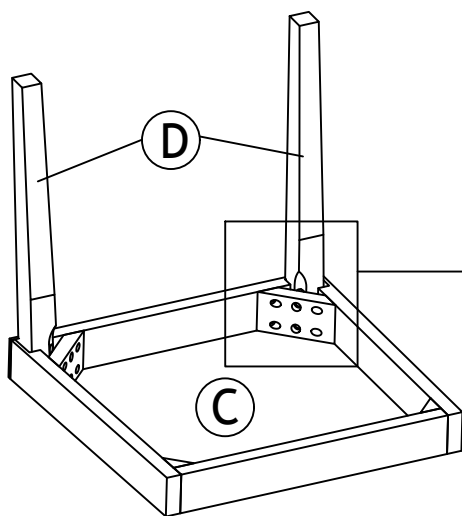

STEP 2

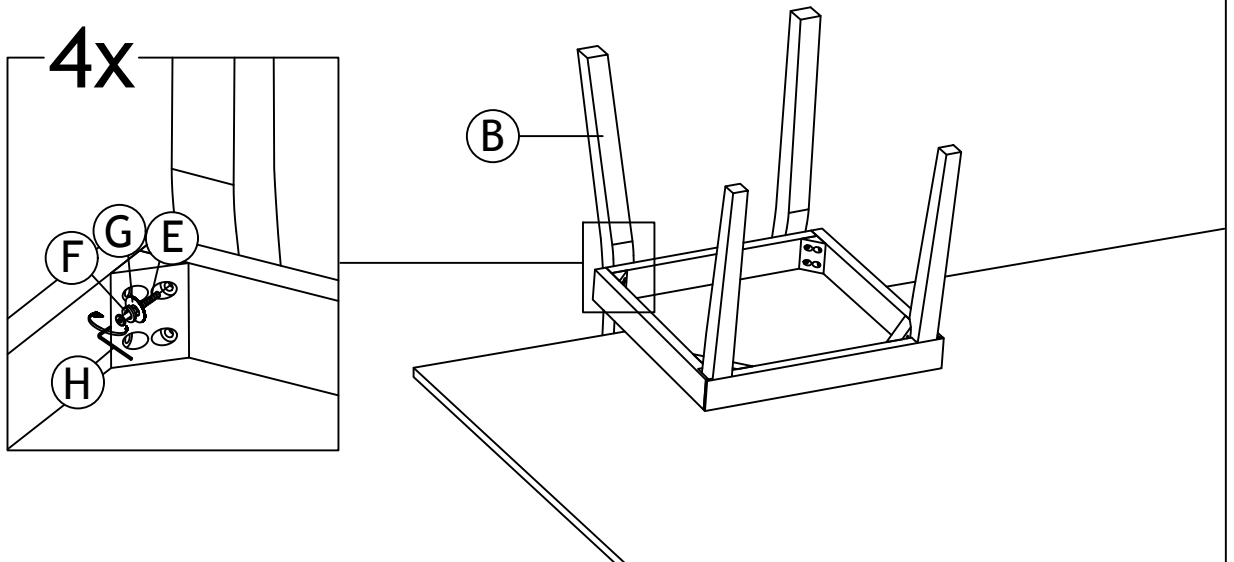

STEP 3

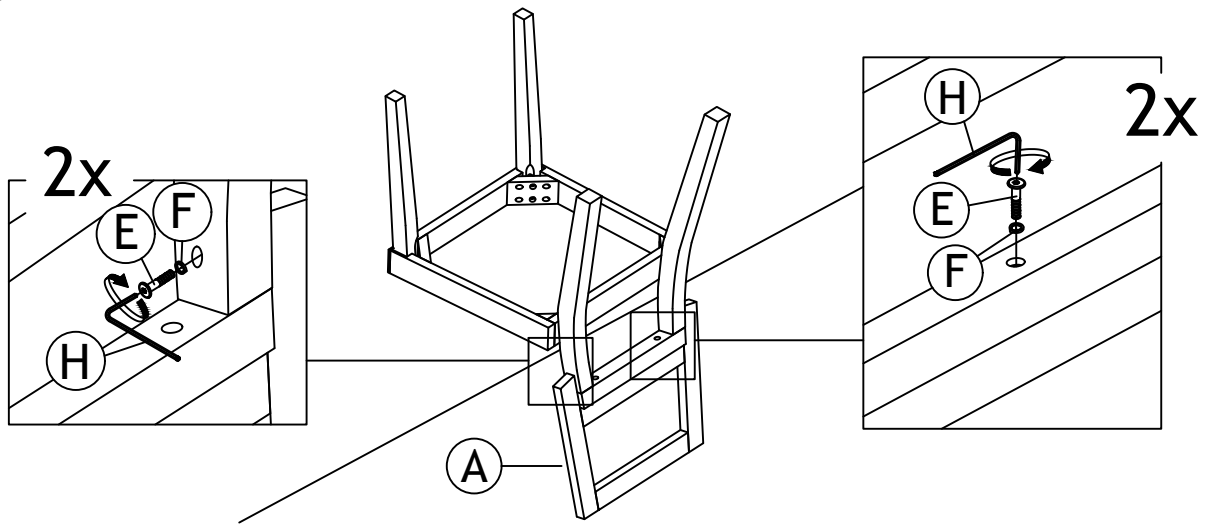

STEP 4

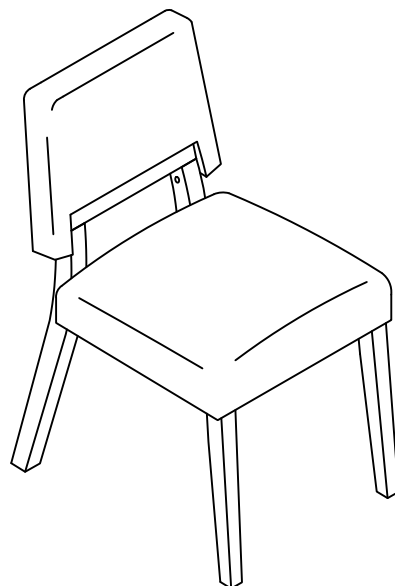







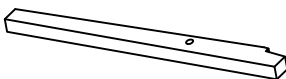
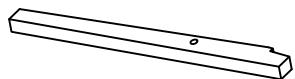
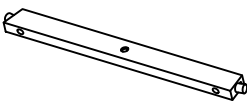
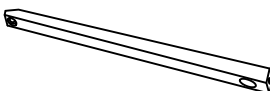

# Product Assembly Instructions

## CHANNELL DINING TABLE

### PART LIST

 <p>A : TABLE TOP x1</p>	 <p>B : TABLE LEG (L) x2</p>	 <p>C : TABLE LEG (R) x2</p>
 <p>D : TABLE LEG STRETCHER x2</p>	 <p>E : TABLE LEG SUPPORT RAIL x2</p>	

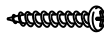
### HARDWARE LIST

 <p>F : JCBC SCREW M6 x 50mm x8</p>	 <p>G : JCBC SCREW M6 x 25mm x4</p>	 <p>H : SPRING WASHER 1/4" x12</p>
 <p>I : FLAT WASHER 1/4" x8</p>	 <p>J : PAN HEAD SCREW M5 x 32MM x4</p>	 <p>K : ALLEN KEY M4 x1</p>

### STEP 1

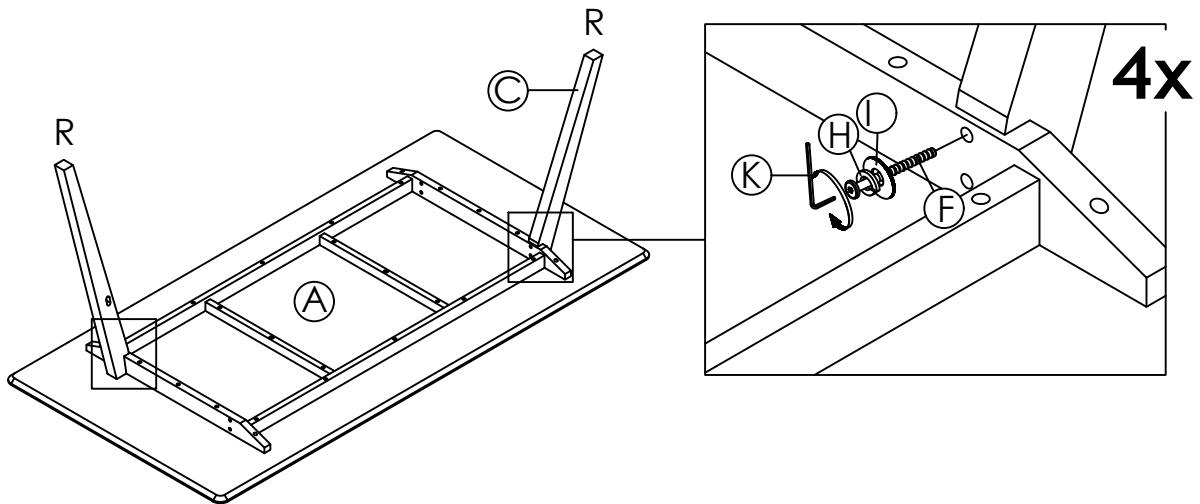

STEP 2

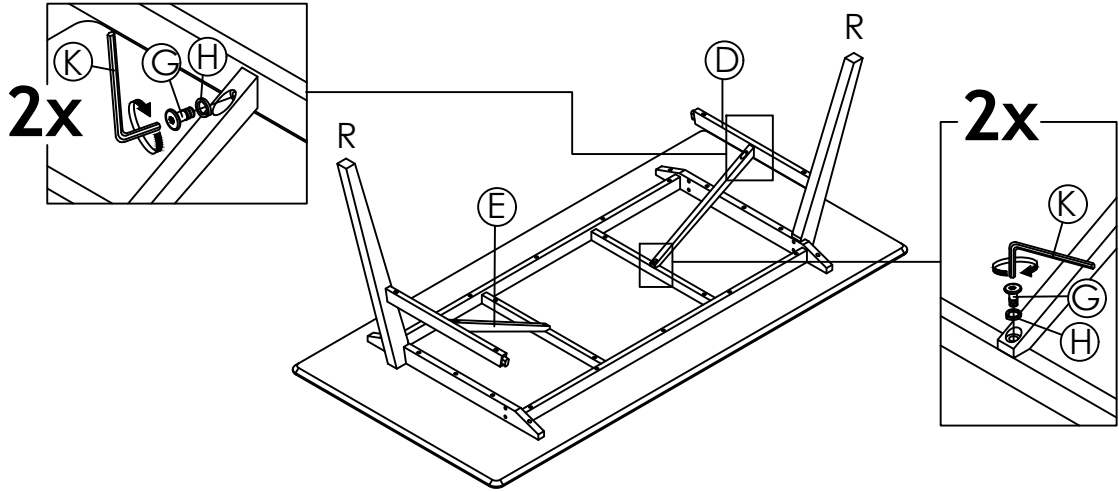

STEP 3

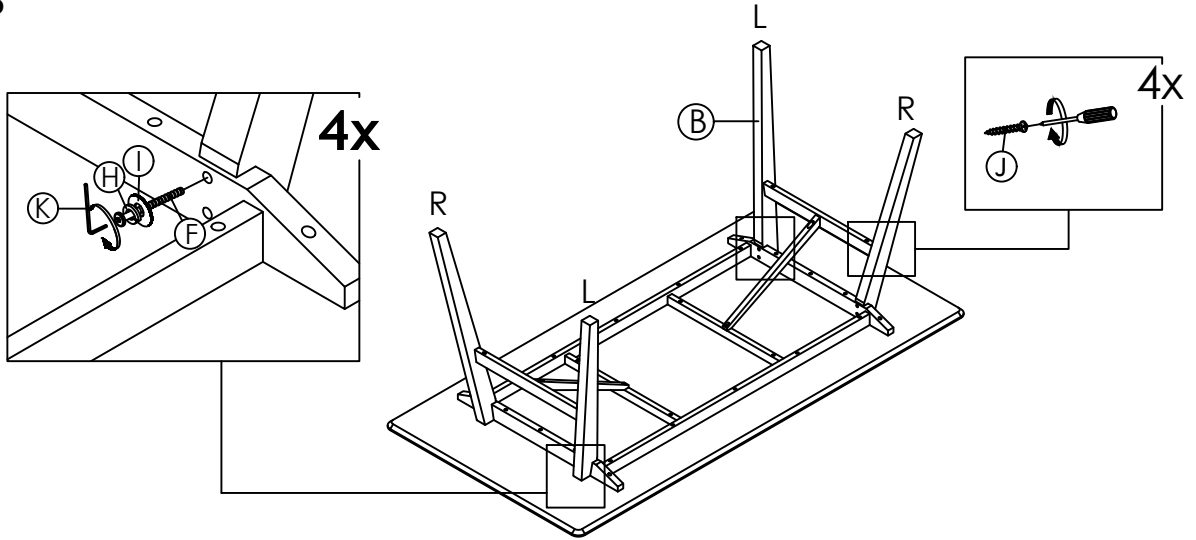

STEP 4

