

## Product Assembly Instructions

# Item#: AMANDA BAR HEIGHT TABLE AMANDA COUNTER HEIGHT TABLE

**Helpers needed to assemble: 2**

**Estimated time frame to assemble: 15 minutes**

Thank you for purchasing this quality product. Be sure to check all packing material carefully for small parts, which may come loose inside the carton during shipment. Please identify and count all parts and compare with the HARDWARE LIST below.

**Caution:** Please read instructions carefully before unpacking assembly parts. Sharp, exposed staples can cause injury, therefore, for your protection, please remove any exposed staples used in packing.

\* Retain the Allen key for regular maintenance. We recommend tightening all screws every three months to ensure continued stability and performance. \*

Before beginning assembly, place all parts on a smooth, flat surface.

### Step 1:

- Place the **table top (A)** upside down on a soft, clean surface.
- Insert **6 threaded rods Ø5/16" × 885 mm (D)** into the table top.
- Hand-tighten all threaded rods until fully secure.

### Step 2:

- Insert the **2 legs (C)** onto the **threaded rods (D)**.





### Step 3:

- Align the holes in the **table base (B)** with the **threaded rods (D)**.
- Place the **table base (B)** onto the **legs (C)**.
- Secure using **6 sleeve nuts 5/16" × 15 mm (1)** and **6 flat washers (2)**.
- Tighten securely with the provided **Allen key (3)**.

Your Amanda Height Table is now complete. Turn the table upright and ensure it sits firmly on the floor by adjusting the levelers.

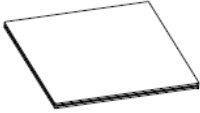
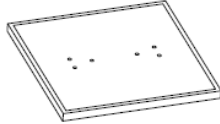
### Assembly Complete!

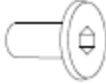
Enjoy your new **Amanda Height Table**.

#	Picture	Description	Q'T Y.
A		Table Top	1
B		Table Base	1
C		Leg	2
D		5/16" x 885 mm Threaded Rod	6
1		5/16" x 15 mm Sleeve Nut	6
2		Ø25 / Ø10mm Flat Washer	6
3		Allen key	1

**STEP 1**

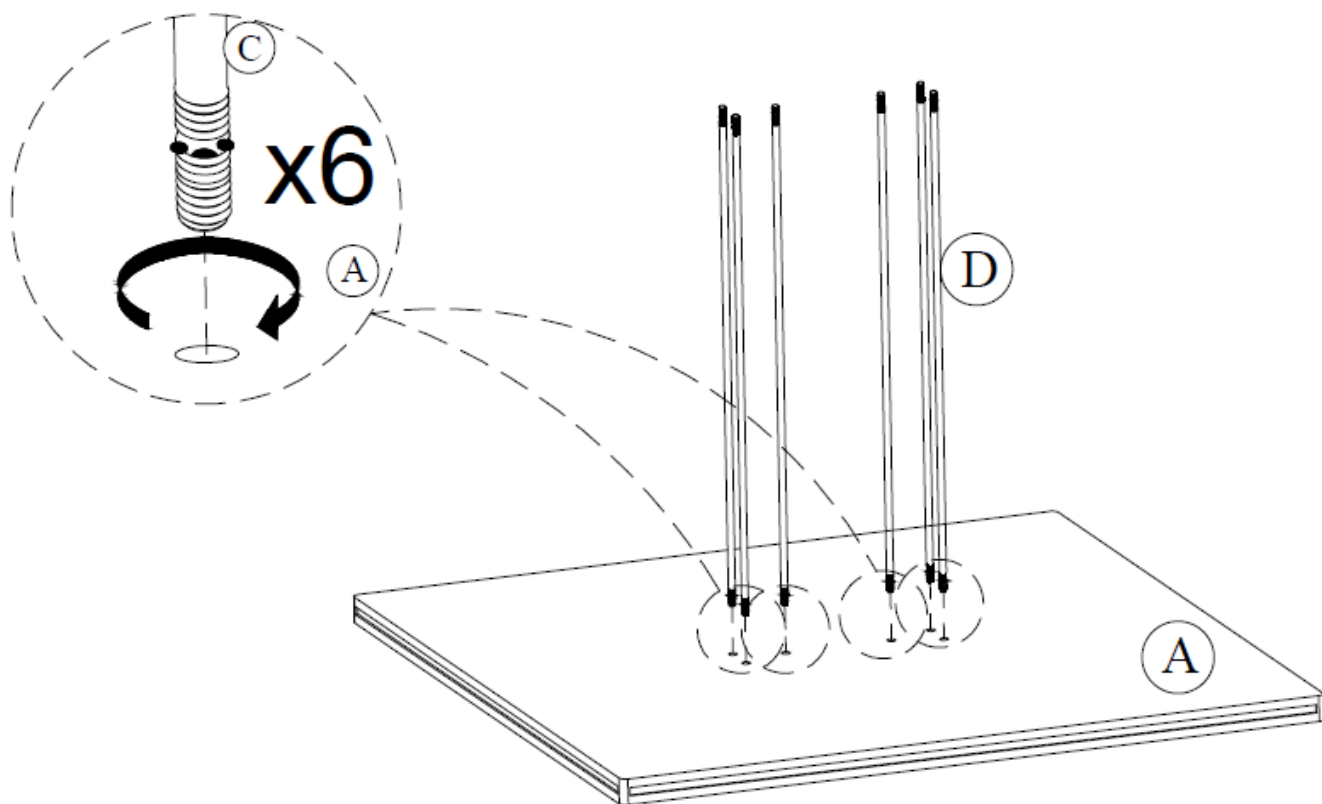

**STEP 2**

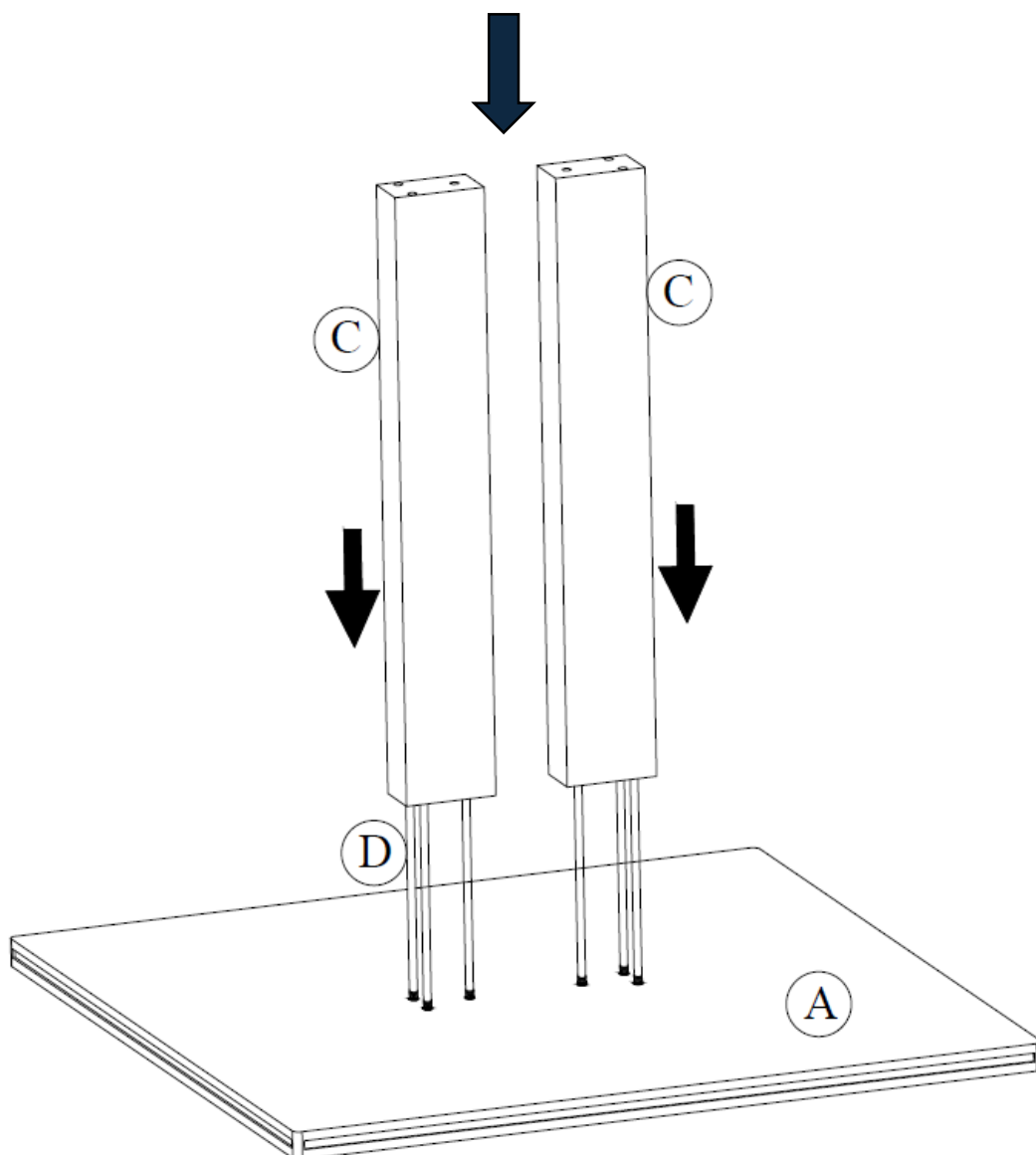

**STEP 3**

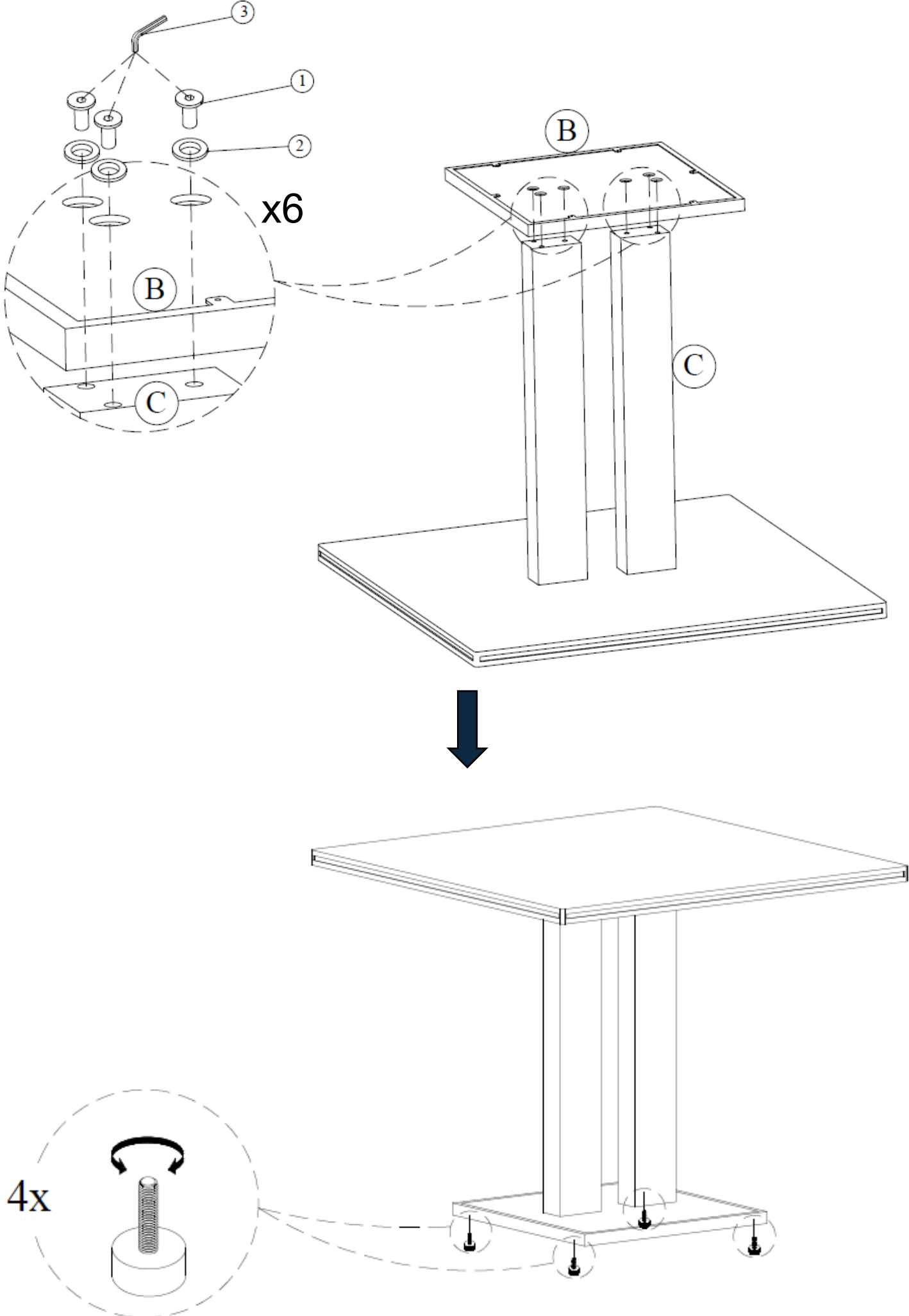

# Product Assembly Instructions

## Item#: AMANDA BARSTOOL

**Helpers needed to assemble: 2**

**Estimated time frame to assemble: 10 minutes**

Thank you for purchasing this quality product. Be sure to check all packing material carefully for small parts, which may come loose inside the carton during shipment. Please identify and count all parts and compare with the **HARDWARE LIST** below.

**Caution:** Please read instructions carefully before unpacking assembly parts. Sharp, exposed staples can cause injury, therefore, for your protection, please remove any exposed staples used in packing.

**\* Retain the Allen key for regular maintenance. We recommend tightening all screws every three months to ensure continued stability and performance. \***

Before beginning assembly, place all parts on a smooth, flat surface.

### Step 1 :

- Begin by assembling the **backrest (B)** to the **leg frame (A)** using **2 pcs Ø1/4" × 10 mm bolts (1)** on each side with the provided **Allen key (5)**.
- Tighten all bolts securely.









### Step 2:

- Attach the **seat (C)** to the leg frame using **2 pcs Ø1/4" × 25 mm bolts (2)** and **2 pcs flat washers (4)** on the back rail, as shown in the diagram.
- Next, attach **2 pcs Ø1/4" × 32 mm bolts (3)** to the front rail.

Repeat on the other side and secured tighten all bolts.

### Assembly Complete!

Enjoy your new **Amanda Barstool**.

#	Picture	Description	Q'TY.
A		Leg Frame	1
B		Backrest	1
C		Seat	1
1		Ø1/4" x 10 mm Bolt	4
2		Ø1/4" x 25 mm Bolt	2
3		Ø1/4" x 32 mm Bolt	2
4		Ø19/ Ø7 mm Flat washer	2
5		Allen key	1

STEP 1

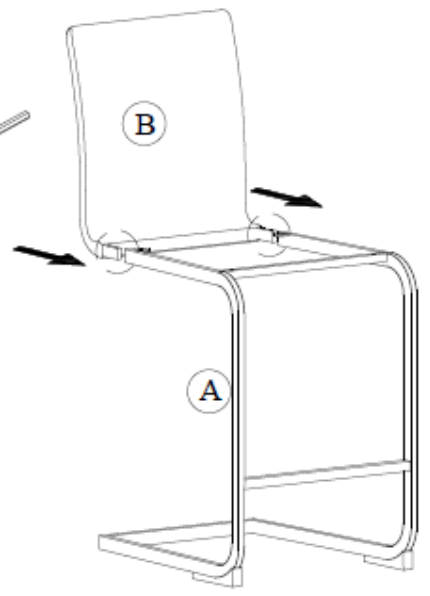
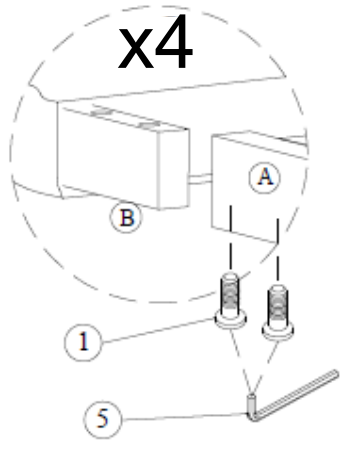

STEP 2

