

Product Assembly Instructions

Item#: WINSLOW BARSTOOL

Helpers needed to assemble: 2

Estimated time frame to assemble: 10 minutes

Thank you for purchasing this quality product. Be sure to check all packing material carefully for small parts, which may come loose inside the carton during shipment. Please identify and count all parts and compare with the **HARDWARE LIST** below.

Caution: Please read instructions carefully before unpacking assembly parts. Sharp, exposed staples can cause injury, therefore, for your protection, please remove any exposed staples used in packing.

* **Retain the Allen key for regular maintenance. We recommend tightening all screws every three months to ensure continued stability and performance. ***

Before beginning assembly, place all parts on a smooth, flat surface.





Step 1 – Attach Seat Frame

- Place the **Leg Frame (A)** upside down on a soft surface.
- Attach the **Seat Frame (B)** to the **Leg Frame (A)**.
- Secure using **Ø1/4" x 44 mm bolts (1)**, **flat washers (2)**, and **spring washers (3)**.
- Ensure all holes are properly aligned before fully tightening the bolts.
- Tighten securely using the provided **Allen key (4)**.

Step 2 – Install Cushion

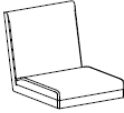
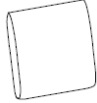
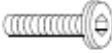
- Turn the barstool upright.
- Place the **Pillow (C)** onto the **Seat Frame (B)**.

Assembly Complete — Enjoy your Winslow Barstool!

#	Picture	Description	Q'TY.
A		Leg Frame	1
B		Seat Frame	1
C		Pillow	1
1		Ø1/4" x 44 mm Bolt	4
2		Ø16/Ø6 Flat washer	8
3		Ø1/4" Spring washer	8
4		Allen key	1

STEP 1

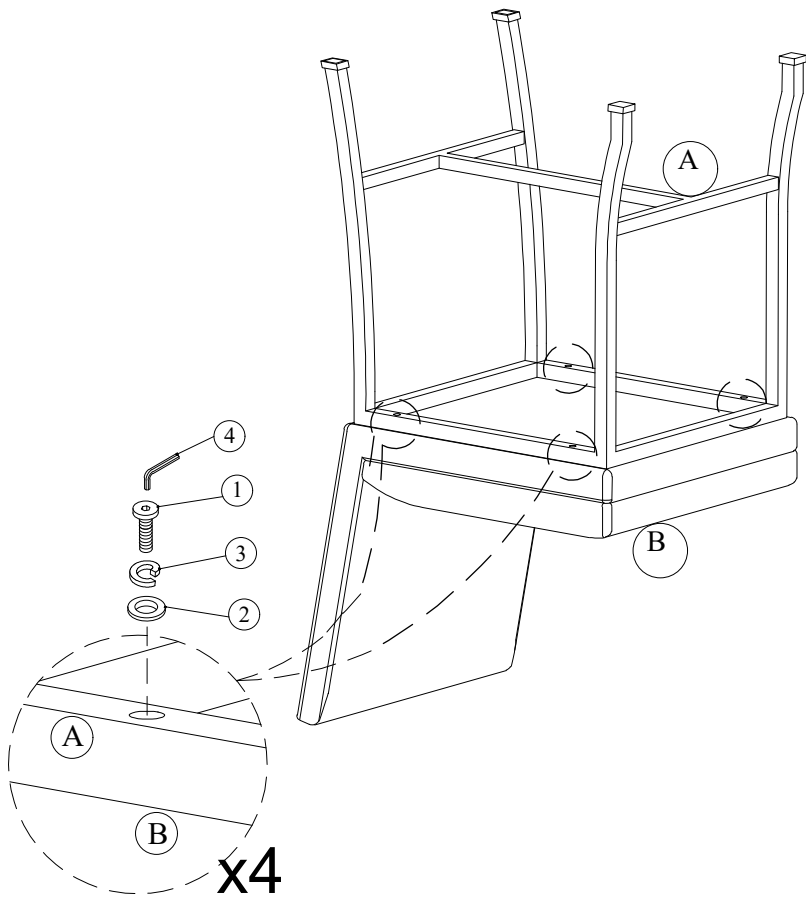

STEP 2

