

Product Assembly Instructions





Item # : VELENA 26" BARSTOOL
VELENA 30" BARSTOOL



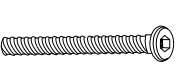

Thank you for purchasing this quality product. Be sure to check all packing material carefully for small parts, which may come loose inside the carton during shipment . Please identify and count all parts and compare with the HARDWARE LIST below.

Caution : Please read instructions carefully before unpacking assembly parts. Sharp , exposed staples can cause injury , therefore , for your protection , please remove any exposed staples used in packing.

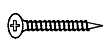
*** Retain the Allen key for regular maintenance. We recommend tightening all screws every three months to ensure continued stability and performance. ***

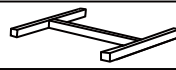
1. We recommend to assemble this product with the assistance of another person. This will provide a smooth assembly process , and can help eliminate self injuries or damage to the product during assembly.
2. Please do not over tighten screws or bolt until the assembly is completed.
3. Please put all parts on a smooth , flat surface before assembly , and carefully follow the assembly steps to assemble your newly purchased correctly and efficiently.

HARDWARE LIST			
NO.	COMPONENT		Qty.
1		JCBC Bolts M6x50mm	8 pcs
2		Spring Washer	8 pcs
3		Flat Washer	8 pcs
4		Allen Key	1 pc
5		Wood Screw M4x32mm	4 pcs

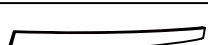
PARTS LIST			
NO.	COMPONENT		Qty.
A		Seat	1 pc
B		Stretcher	1 pc
C		Right Front Leg Labeled 'R'	1 pc
D		Left Front Leg Labeled 'L'	1 pc
E		Left Back Leg Labeled 'L'	1 pc
F		Right Back Leg Labeled 'R'	1 pc

* Philips screwdriver not included *

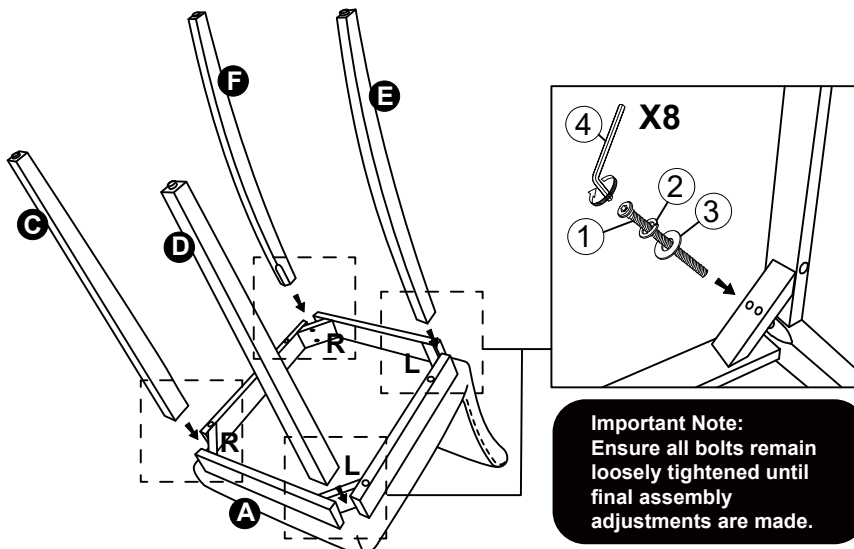

Important Note:
Ensure all bolts remain loosely tightened until final assembly adjustments are made.

Step 1:

Attach Right Front Leg (C) and Left Front Leg (D) to the correct front corners of Seat (A) using Bolt (1), Spring Washer (2) and Flat Washer (3). Loosely tighten with Allen Key (4) provided.

Step 2:

Attach Right Back Leg (F) and Left Back Leg (E) to the correct back corners of Seat (A) using Bolt (1), Spring Washer (2) and Flat Washer (3), Loosely tighten with Allen Key (4).

Do not fully tighten from Step 1 & 2.

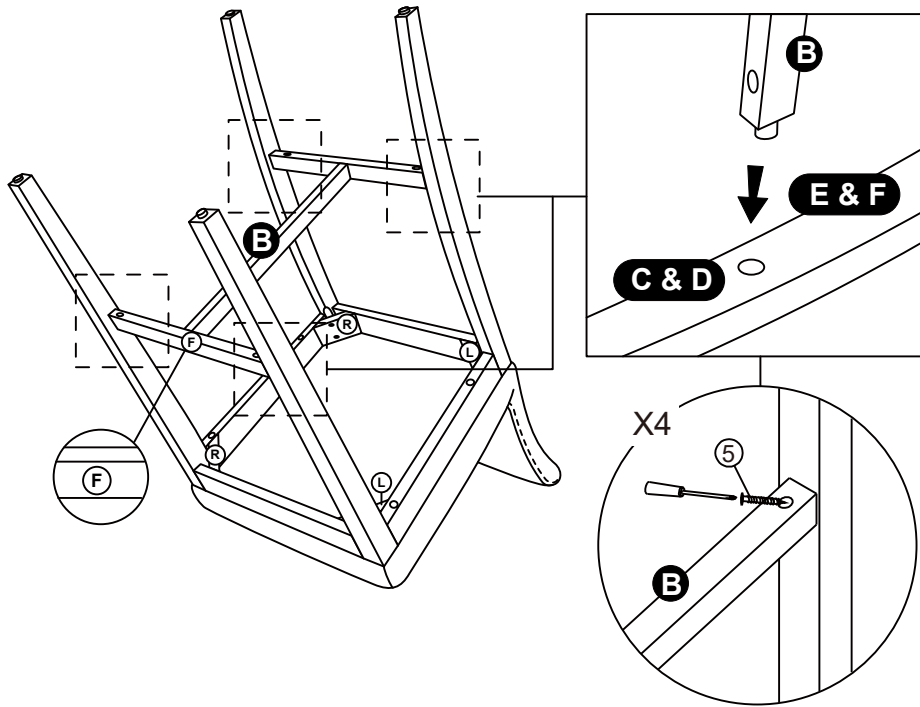

Step 3:

Attach Stretcher (B) to the front and back legs. Ensure the labeled F faces the front legs.

Step 4:

Next insert Wood Screw (5) to the holes and tighten securely with Phillip screwdriver (not provided)

NOTE: ENSURE ALL LEGS ARE LEVEL TO THE FLOOR BEFORE FULLY TIGHTENING ALL BOLTS.

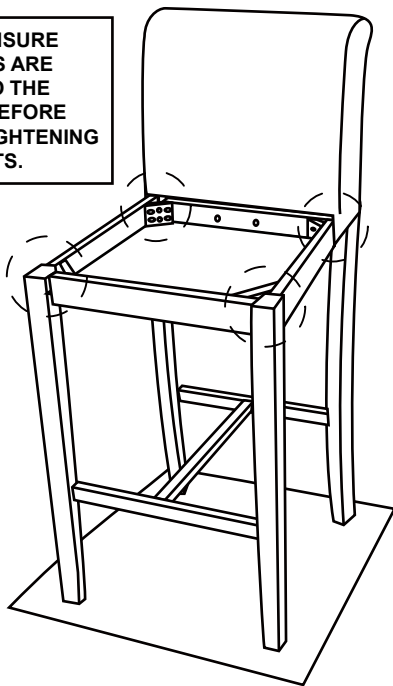

YOUR ASSEMBLY IS COMPLETE

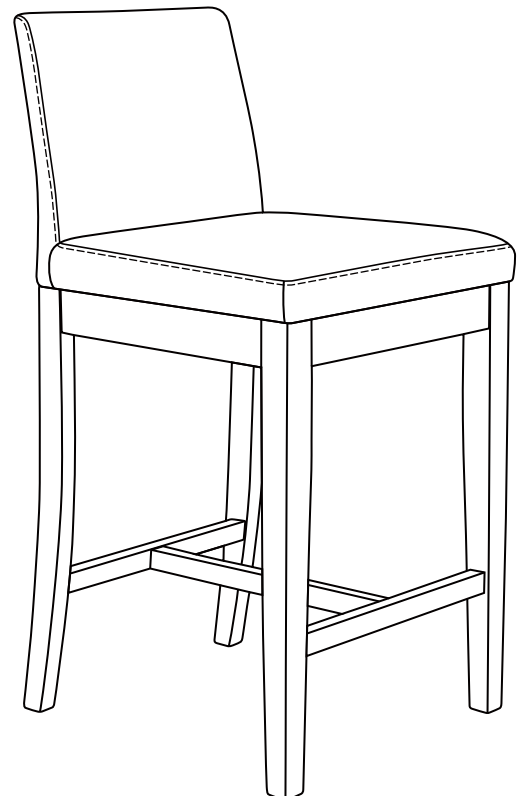

Step 5:

1. Place the barstool on a flat, level surface.
2. Check that all legs make even contact with the floor. If uneven, adjust the Box Seat by tilting as needed.
3. Once level, securely tighten all bolts.