

Product Assembly Instructions

LCPIBUAC

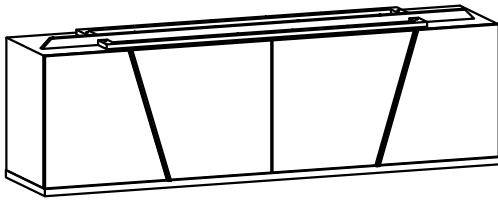

A: Cabinet x 1

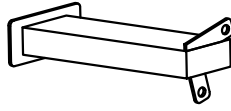

B1: Left Leg x 2

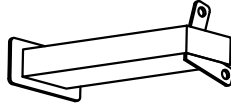

B2: Right Leg x 2

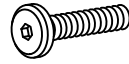

C: Bolts M6*15mm x 8



D: Lock Washer M8 x 8



E: Plate Washer M8*Ø18mm x 8

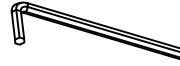

F: Allen wrench K4 x 1

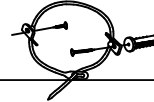

G: Anti-Tip Kit x 2

STEP 1

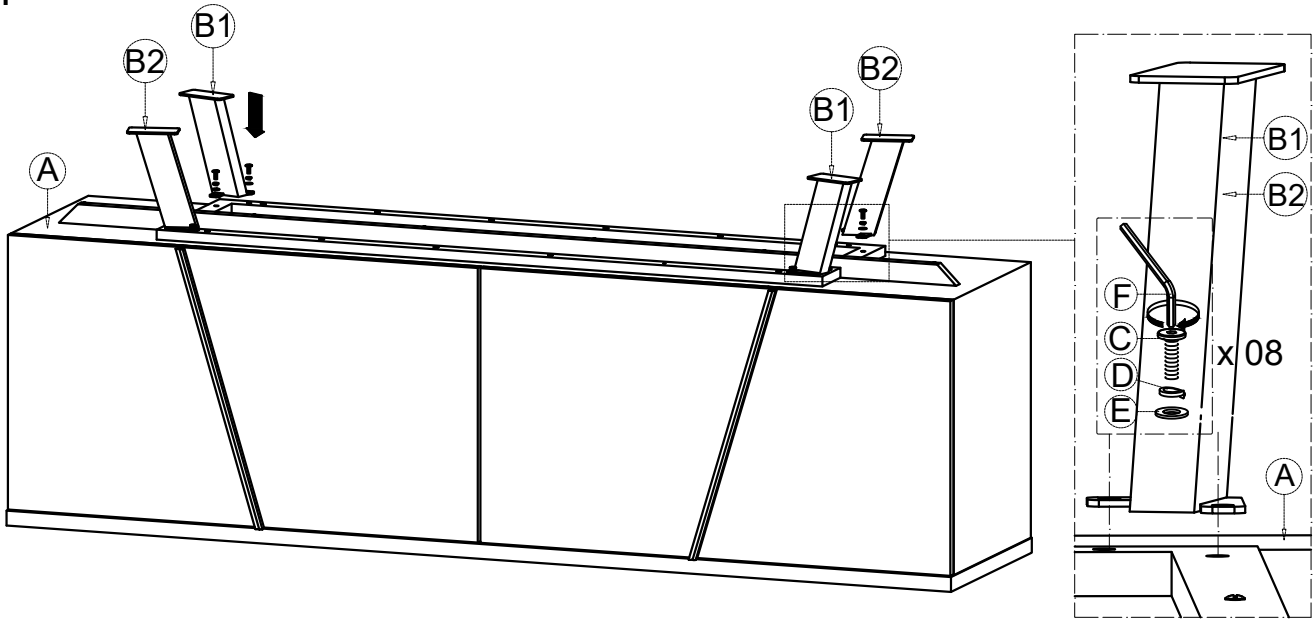

STEP 2

