

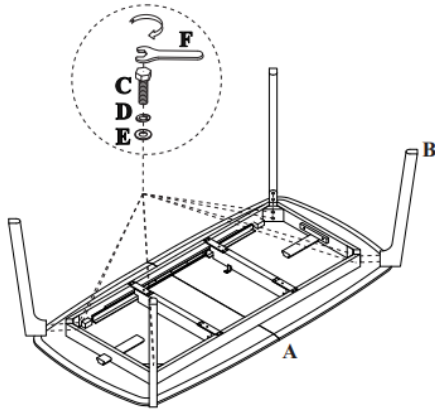





# PRODUCT ASSEMBLY INSTRUCTIONS

## Item#: HOLLAND EXTENSION DINING

Helpers needed to assemble: 2

Estimate time frame to assemble: 30 minutes



#	Picture	Description	Quantity
A		Tabletop	1
B		Legs	4
C		Bolt – M10 x 80mm	8
D		Spring Washer – M10	8
E		Flat Washer – M10	8
F		Wrench – M17	1

- **Step 1:** Place the tabletop upside down on the floor as seen. Make sure it's on a safe surface where the table cannot be scratched and or damaged.
- **Step 2:** Align the table leg with the tabletop holes as seen.
- **Step 3:** Identify the first leg and the obtain (2 bolts; 2 flat washers; 2 spring washers) Using the M17 wrench bolt down the first leg onto the inside of the table as seen in the diagram.
- **Step 4:** Using the wrench you will tighten the bolt until the leg is firmly attached.
  - Repeats Steps 2-4 for each leg.

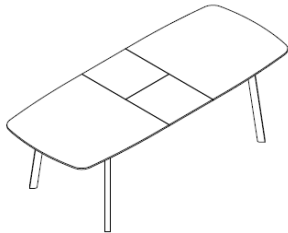

- **Step 5:** Flip the table over upright as seen.
- **Step 6:** Test the table is firmly on the ground and the table does not wobble.
- **Step 7:** Sit and enjoy your new table.

### Extension Table Instructions

- **Step 8:** Unlock The clips on both side of the table under the mid parting section and pull the two side of the panel apart as seen in the diagram to expose the middle extension.
- **Step 9:** Flip the extension panel as seen in the diagram out to lay flat and align with the rest of the table. The middle extension will then allow you to flip the second panel to complete the extension table.
  - Note the extension panels should be flipped together at the same time.
  - This can be broken if done incorrectly and tried to split by panel and then flip separately.
- **Step 10:** Align the two sideboards and the middle extension panels holes as seen. Push the side panels in and adjust to reunite the parts of extension panel and two side panels until you remove any spacing in between the extension and side panels. Lock the clips into place. Enjoy your new extension table!

