

Product Assembly Instructions

Item#: CELINA BARSTOOL

Helpers needed to assemble: 2

Estimated time frame to assemble: 10 minutes

Thank you for purchasing this quality product. Be sure to check all packing material carefully for small parts, which may come loose inside the carton during shipment. Please identify and count all parts and compare with the **HARDWARE LIST** below.

Caution: Please read instructions carefully before unpacking assembly parts. Sharp, exposed staples can cause injury, therefore, for your protection, please remove any exposed staples used in packing.

* Retain the Allen key for regular maintenance. We recommend tightening all screws every three months to ensure continued stability and performance. *

Before beginning assembly, place all parts on a smooth, flat surface.

Step 1 - Attach Backrest.









- Attach the **backrest (B)** to the **leg frame (A)** using **Ø1/4" x 16 mm bolts (1)** with **flat washers (3)** and **spring washers (4)** on each side.
- Use the provided **Allen key (5)** and tighten all bolts securely.

Step 2 - Attach Seat.

- Attach the **seat (C)** to the **leg frame (A)**. Place the stool upside down on a soft surface to avoid damage.
- Secure using **Ø1/4" x 25 mm bolts (2)** with **flat washers (3)** and **spring washers (4)**.
- Ensure all holes are properly aligned before fully tightening.

Assembly Completed!

Your barstool is now ready for use.

#	Picture	Description	Q'TY.
A		Leg Frame	1
B		Backrest	1
C		Seat	1
1		Ø1/4" x 16 mm Bolt	4
2		Ø1/4" x 25 mm Bolt	4
3		Ø16/Ø6 Flat washer	8
4		Ø1/4" Spring washer	8
5		Allen key	1

STEP 1

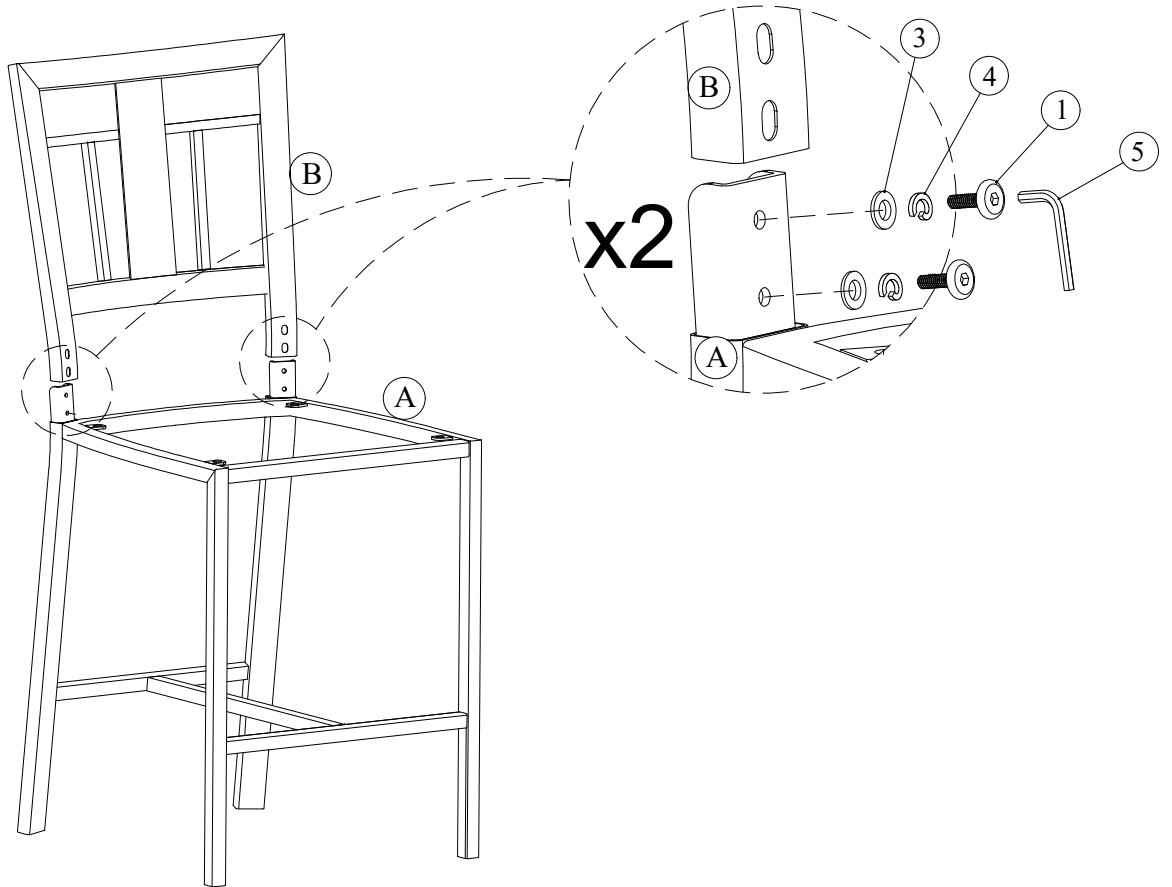

STEP 2

